

## CHAPTER 1: OVERALL UNIT

### MODULE A: NUCLEAR POWER PLANT SAFETY

#### **MODULE OBJECTIVES:**

At the end of this module, you will be able to describe:

1. The main energy conversions from fission to electricity in a nuclear generating unit;
2. State and explain the golden rule of reactor safety;
3. Define and explain the significance of the ALARA principle;
4. State what is meant by Defense in Depth, and describe the five parts of the Defense in Depth model;
5. Explain how each of the five barriers protect the public from fission products.

## 1. INTRODUCTION

- The purpose of a nuclear plant is to allow the safe and economic conversion of the fission energy of fuel to electricity, with a minimum impact on the environment.

### 1.1 CONVERSION OF FUEL (MASS) TO ELECTRICITY:

- input to the system is fuel, in the form of fissile material (Uranium);
- fission takes place in the reactor under suitable conditions: this course is restricted to thermal reactors, hence a moderator must be present;
- the energy liberated by fission appears in the form of heat: heat must be removed continuously to prevent fuel failure and the release of radioactivity;
- the heat is used to boil water as in any other thermal power plant: the steam generator is the primary heat sink for the energy released by the fuel;
- the steam energy is converted to kinetic energy by spinning a turbine;
- the kinetic energy of the turbine is converted to electricity in the generator;
- the output of the system is electricity to the electric power system.

### 1.2 PHYSICAL PROCESSES TO BE CONTROLLED:

- fission
- heat transfer
- flow
- pressure
- temperature
- change of state



Figure 1: Main Energy Conversion Stages in a Nuclear Power Plant

## 2. SAFETY OF NUCLEAR POWER PLANTS

### 2.1 RADIATION HAZARD

- the unique safety concern with nuclear power plants is the exposure to radiation;
- the probable causes of radiation hazards are the same as for conventional hazards:
  - ⇒ design errors
  - ⇒ manufacturing flaws
  - ⇒ construction and installation mistakes
  - ⇒ operating and maintenance errors
  - ⇒ equipment failures.

### 2.2 ALARA Principle

- all hazards must be reduced to a level that is “As Low As Reasonably Achievable”  
this is known as the **ALARA Principle**;
- the main radiation hazard is from the fission products in irradiated fuel.

### 2.3 GOLDEN RULE OF REACTOR SAFETY

- there is a minimum risk to the public and the environment from reactor fuel, provided that at all times:
  - ⇒ the reactor power is controlled;
  - ⇒ the fuel is cooled;
  - ⇒ the radioactivity is contained.
- This rule is often shortened to **CONTROL, COOL, and CONTAIN**, and is referred to as the **GOLDEN RULE OF REACTOR SAFETY**.

### 3. SAFETY STANDARDS

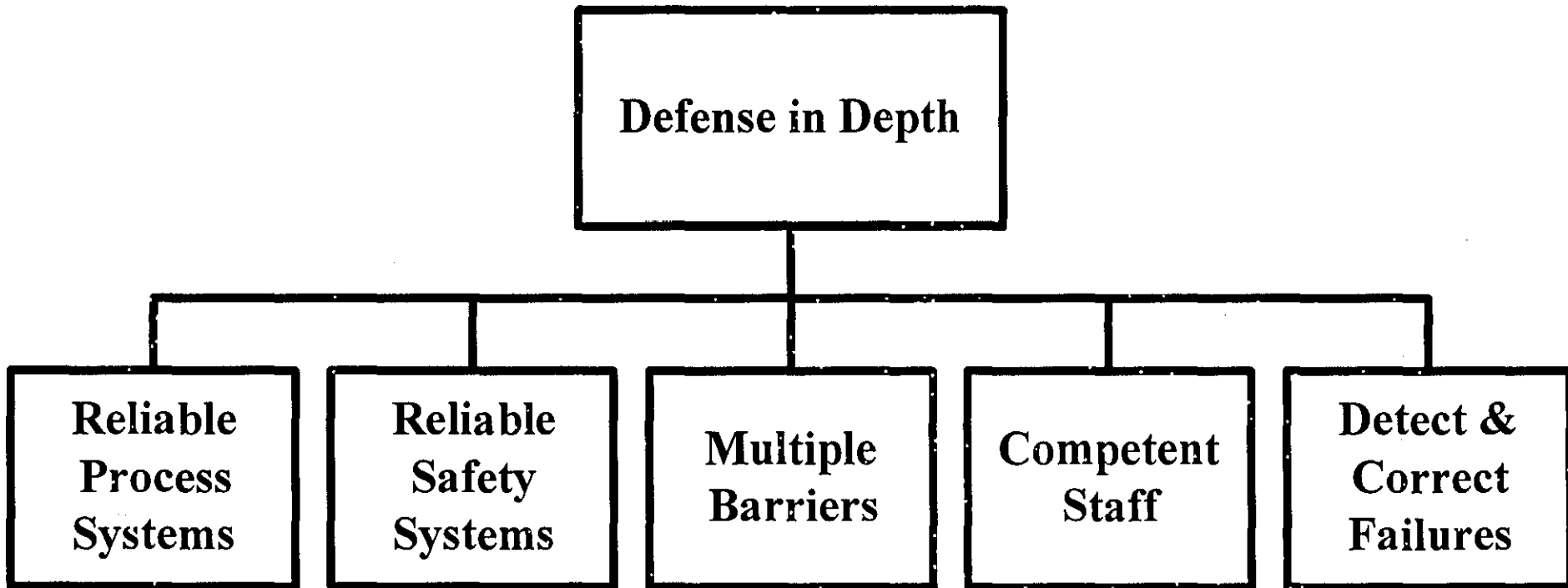
- employees at work should be safer than when they are not at work;
- employees at work in a nuclear generating station should be as safe as the average employee anywhere else in the same utility;
- employees at work in a nuclear generating station should be twice as safe as the average industrial worker in the same jurisdiction;
- employees at work in a nuclear generating station should be as safe as employees in all North American utilities.

#### 3.1 NUMERICAL TARGETS

- employee fatalities < 2 per 100 million worker-hours;
- employee permanent disabilities < 2 per 100 million worker-hours;
- employee temporary disabilities < 0.4 per 200,000 hours worked;
- employee risk of disabling injury < 10 days lost per 200,000 hours worked.

#### 4. DEFENSE IN DEPTH CONCEPTS

It is the principle way the Golden Rule (CONTROL, COOL and CONTAIN) is achieved in the design, construction, commissioning, operation and maintenance of a nuclear power plant.



## 5. RELIABLE PROCESS SYSTEMS

They are the first line of defense, they operate continuously all the processes necessary to ensure that:

- the fission is controlled,
- the fuel is cooled and
- radioactivity is contained

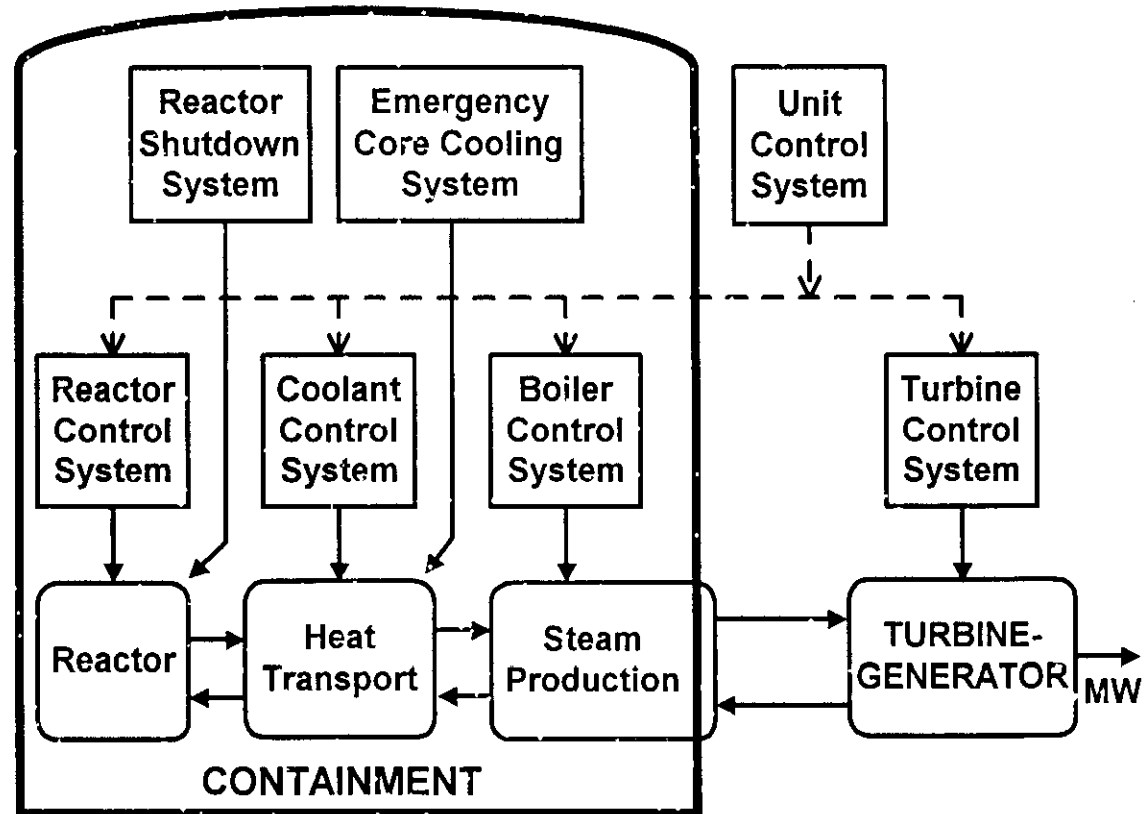
i.e. their purpose is accident prevention;

### 5.1 RELIABLE SAFETY SYSTEMS

They are the second level of ensuring safety, they are “poised” as a back-up in case there are process system failures; they will do one or more of the following:

- shut down the reactor,
- ensure continued cooling of the fuel,
- containment of fission product release.

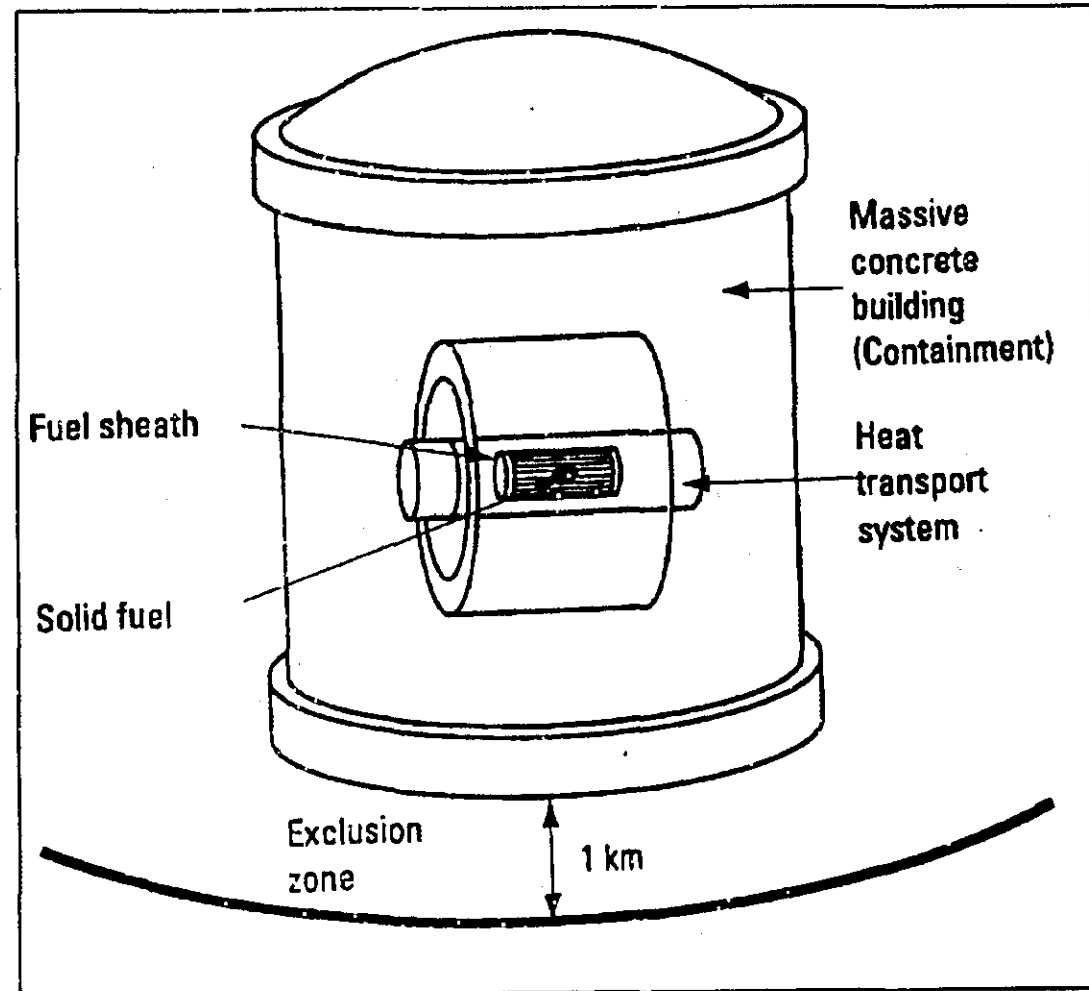
i.e. they provide accident mitigation or accommodation



## 6. MULTIPLE BARRIERS

There are five barriers to radioactivity release from the fuel:

- the uranium fuel is molded into ceramic pellets which have a high melting point and lock in most of the fission products;
- the fuel sheath is made of high integrity welded metal (zircaloy) and contains the ceramic fuel;
- the heat transport system is constructed of high strength pressure tubes, piping and vessels and contains the fuel bundles;
- the containment system provides a relatively leak tight envelope that is maintained slightly below atmospheric pressure;
- the exclusion zone of at least one kilometer radius around the reactor ensures any radioactive releases from the station are well diluted by the time they reach the boundary.



## 7. COMPETENT OPERATING AND MAINTENANCE STAFF

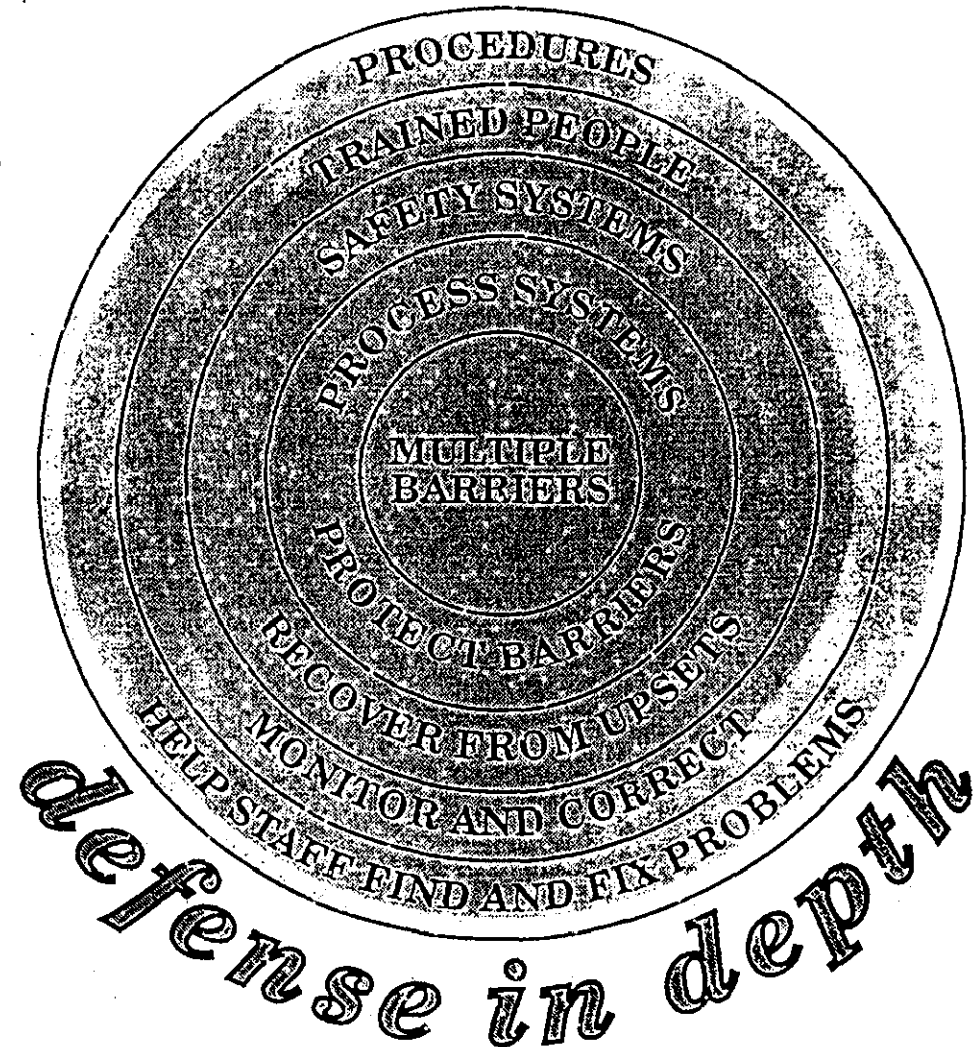
- safety systems are designed to operate automatically
- the five passive barriers are always in place
- operating and maintenance staff monitor system conditions and act to prevent or minimize the consequences of any equipment or system failures.

### 7.1 DETECT AND CORRECT FAILURES

- processes and procedures for the staff to do their work in a systematic fashion
- routine testing programs for safety systems to meet the availability targets
- operational surveillance program
- planned preventive maintenance program
- failures, when they do occur, are thoroughly investigated and solutions applied through a rigorous change approval process.

### 7.2 EFFECTIVENESS OF DEFENSE IN DEPTH AS PRACTICED IN CANADA:

- no fatality and no injury of any member of the public as a result of reactor operations;
- no release of radioactivity from a nuclear power plant that resulted in a measurable dose to the public;
- emission of radioactivity has always been far below the regulatory limits (typically < 1% of limits).





## CHAPTER 1: OVERALL UNIT

### MODULE B: CONTROLLING THE ENERGY CONVERSION PROCESS

#### MODULE OBJECTIVES:

At the end of this module, you will be able to describe:

1. The main energy conversions from fission to electricity in a nuclear generating unit;
2. How an energy balance is maintained between the reactor (or primary) and the conventional (or secondary) side of the station;
3. The two basic methods of controlling a nuclear generating unit;
4. The main control actions under “turbine-leading-reactor” control mode;
5. The main control actions under “reactor-leading-turbine” control mode;
6. The functions of the five main process control systems.

## 1. THE CONTROL PROBLEM - MAINTAINING THE ENERGY BALANCE

### 1.1 Operating Requirements:

- assure safety of public, workers and equipment
- constant power generation at a specified level of output
- change power output to specified levels at specified rates
- maintain generation frequency within specified limits

### 1.2 Disturbances

- load voltage, current and frequency
- steam pressure, flow and quality
- condenser pressure & temperature, cooling water flow and temperature
- reactor coolant flow, pressure and temperature
- reactivity effects: fuel burn-up, fission products, control absorbers, moderator temperature, coolant temperature and void

### 1.3 Indications of Lack of Control

- generator output (MW)
- reactor power level
- coolant temperature and pressure
- steam flow and pressure

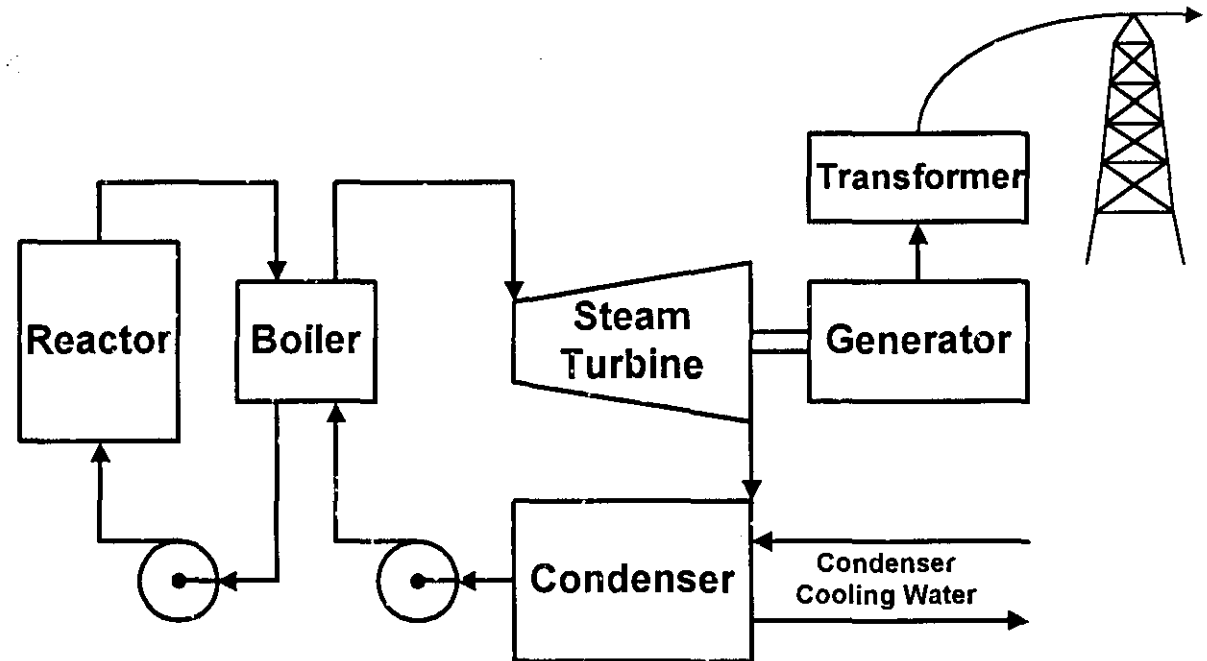


Figure 1: Simplified nuclear power plant block diagram

## 2. NUCLEAR POWER PLANT SIMPLIFIED SCHEMATIC

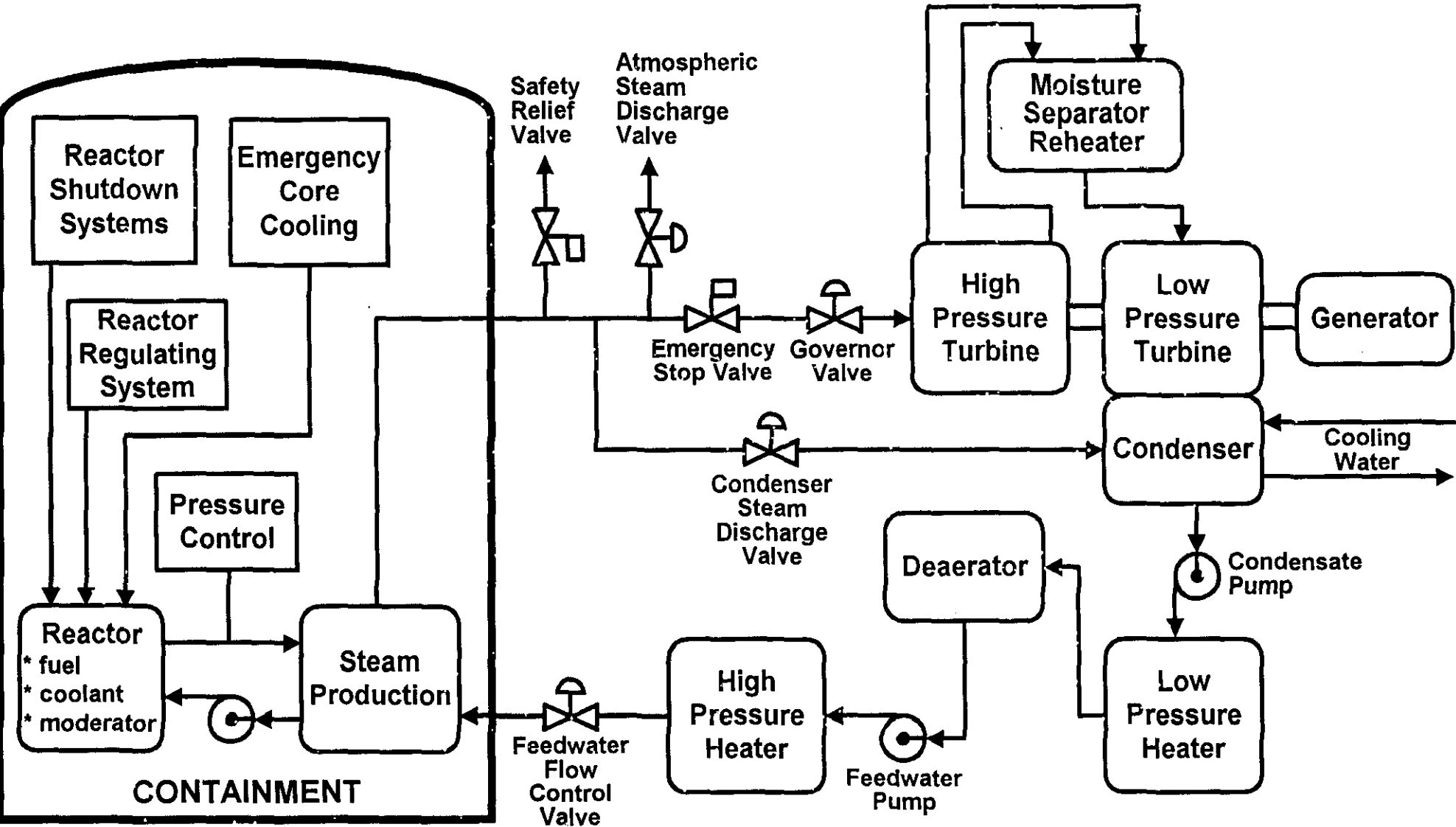


Figure 2: Nuclear plant major process and safety systems

### 3. CONTROL OF UNIT POWER

- if unit output power is specified as the setpoint, unit operates in “turbine-leads-reactor” (or “reactor lagging) mode
- if unit output power is determined by the setpoint of the reactor, unit operation is called “reactor-leads-turbine” (or “reactor leading”) mode
- the choice of unit control mode depends on the operating status of the generating station and the requirements of the electrical power grid

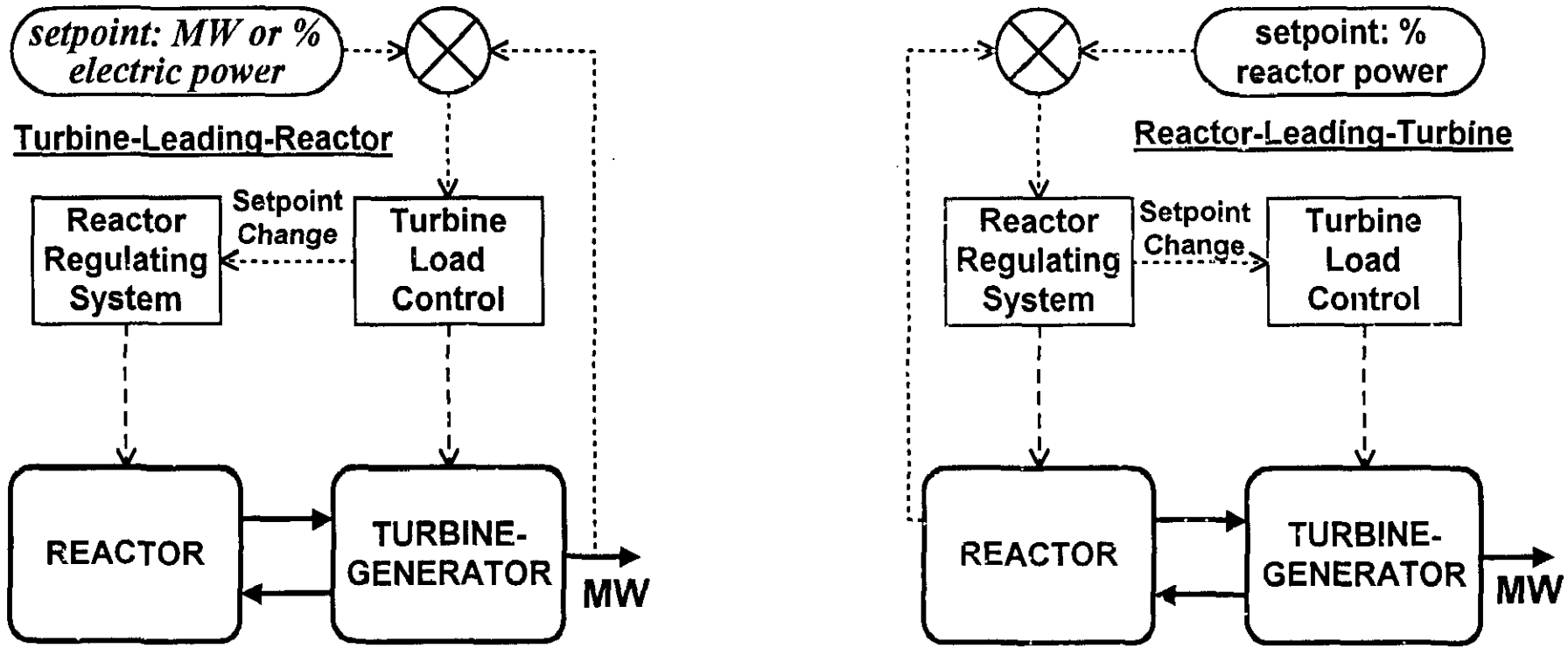


Figure 3: Two basic types of nuclear generating station overall unit control systems

#### 4. TURBINE-LEADING-REACTOR MODE

- the setpoint is the desired level of generator output (megawatts)
- if there is a difference between the setpoint and the actual power level, the control system makes a correction by altering the opening of the governor valve and hence the amount of steam flow going to the turbine
- changes in steam flow will change the steam generator pressure (in the opposite direction)
- the reactor control system adjusts reactor power by changing the position of the reactivity control devices to keep the steam generator pressure at its setpoint

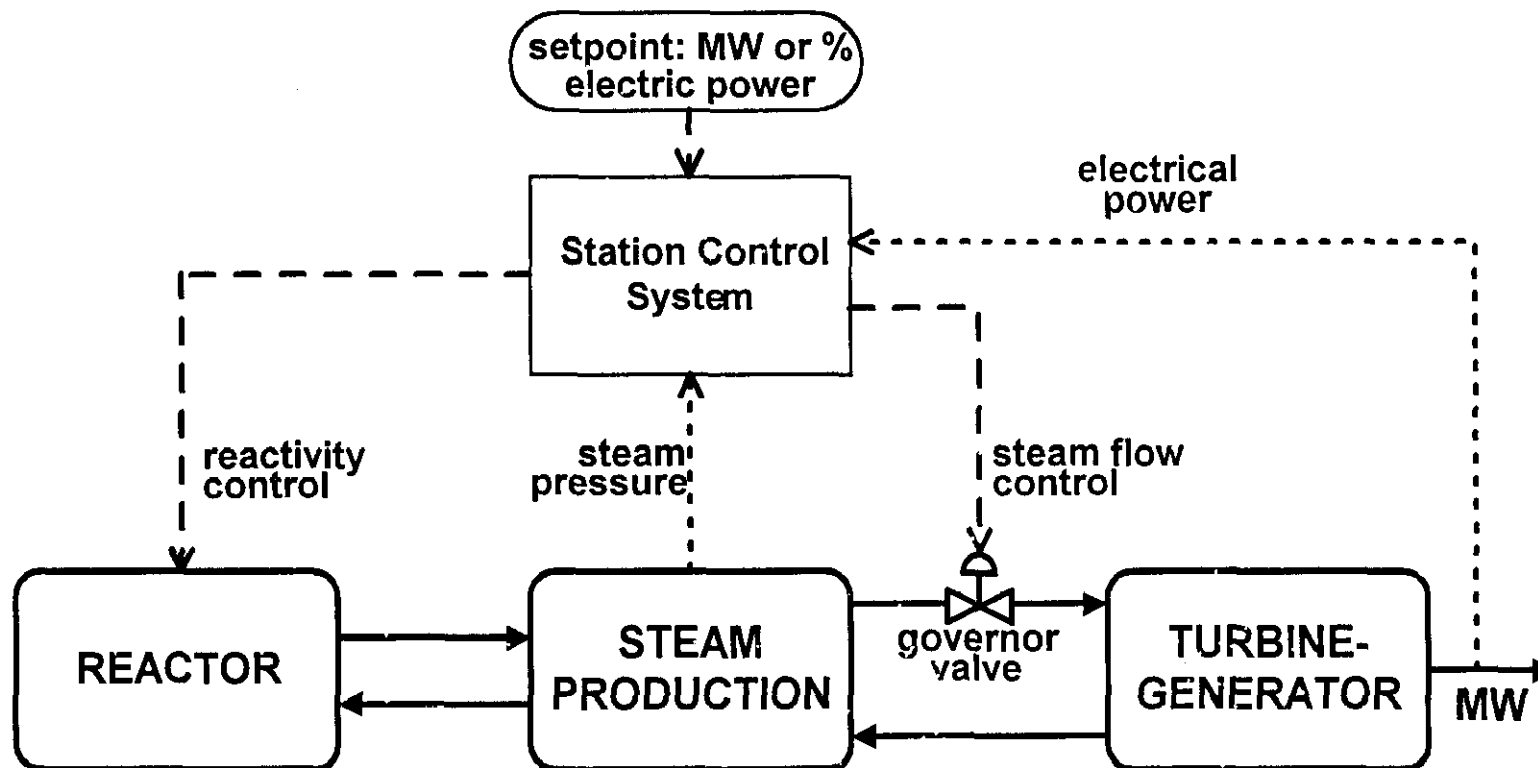


Figure 4: Simplified turbine-leads-reactor overall unit control system

## 5. REACTOR-LEADING-TURBINE MODE

- the setpoint is the desired level of reactor power output
- if there is a difference between the setpoint and the actual reactor power level, the control system makes a correction by altering the position of the reactivity control devices and hence the reactor neutron flux
- changes in reactor power will change the steam generator pressure (in the opposite direction)
- the steam generator pressure control system adjusts steam flow and hence turbine power by changing the position of the governor valve to keep the steam generator pressure at its setpoint

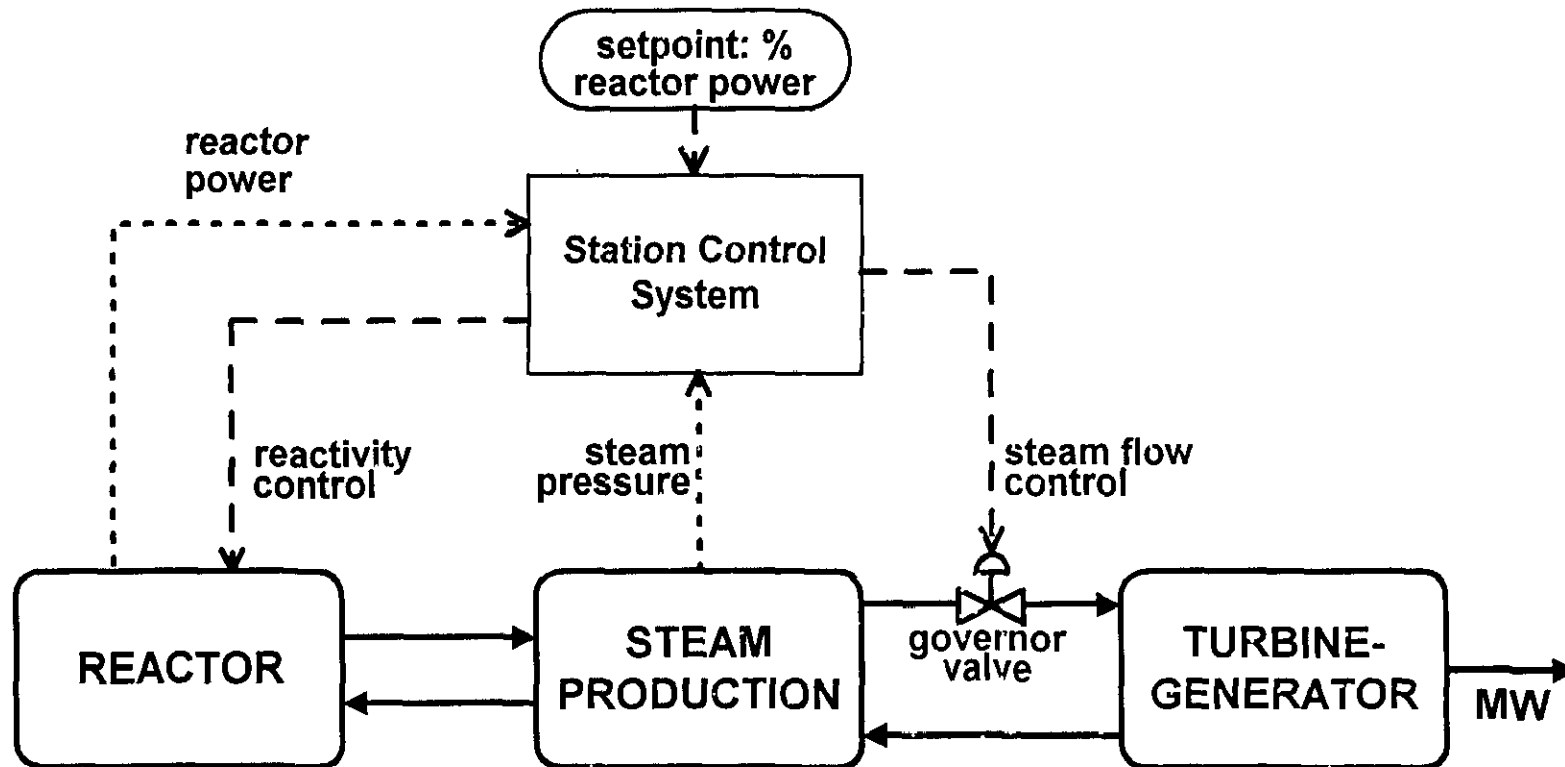
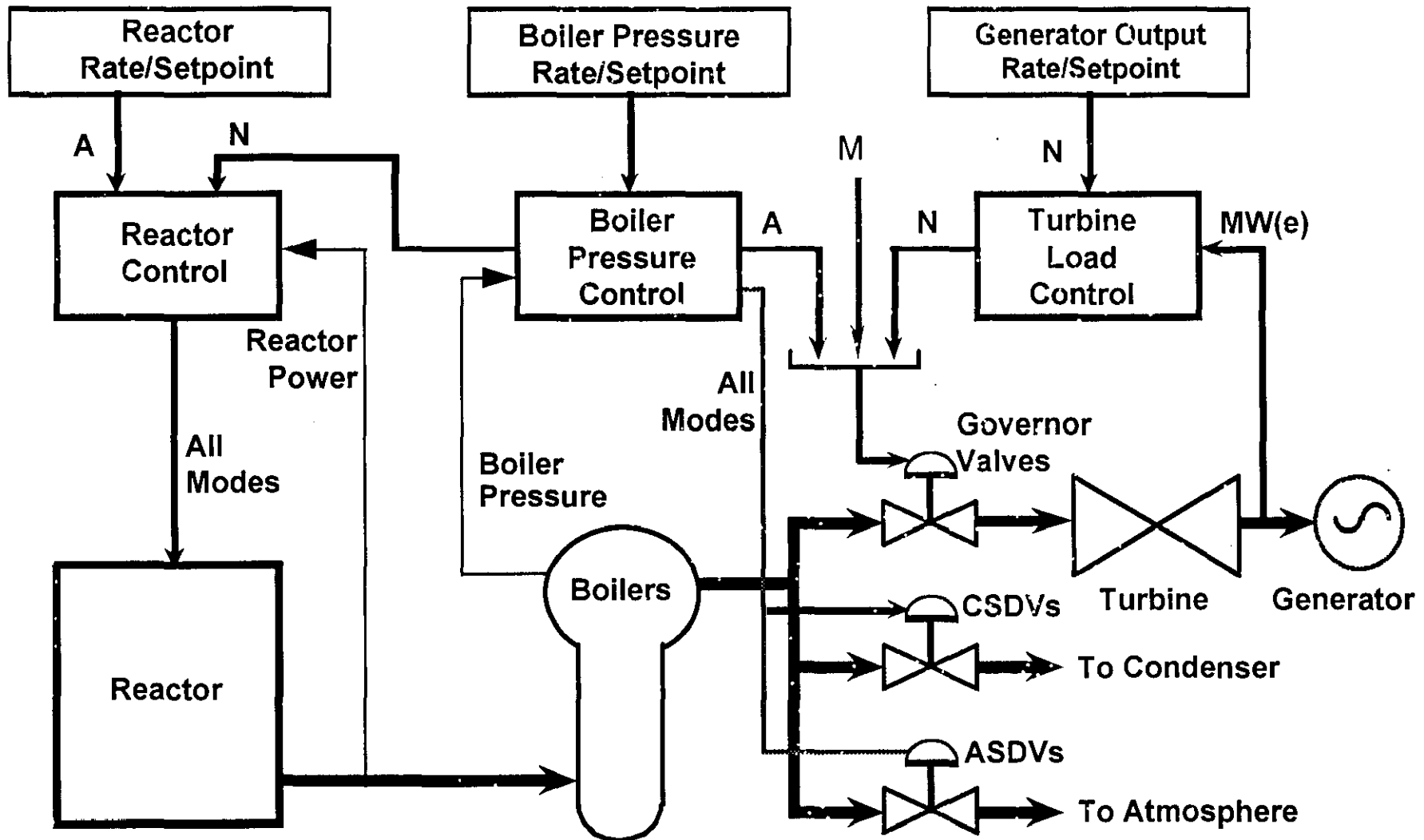


Figure 5: Simplified reactor-leads-turbine overall unit control system

6. CANDU NORMAL AND ALTERNATE MODES OF UNIT CONTROL



N - Normal Mode (Turbine Leading)  
 A - Alternate Mode (Reactor Leading)  
 M - Manual Speeder Gear Operation

Figure 6: CANDU Unit Control Schematic

## 7. CANDU MAIN PROCESS CONTROL SYSTEMS

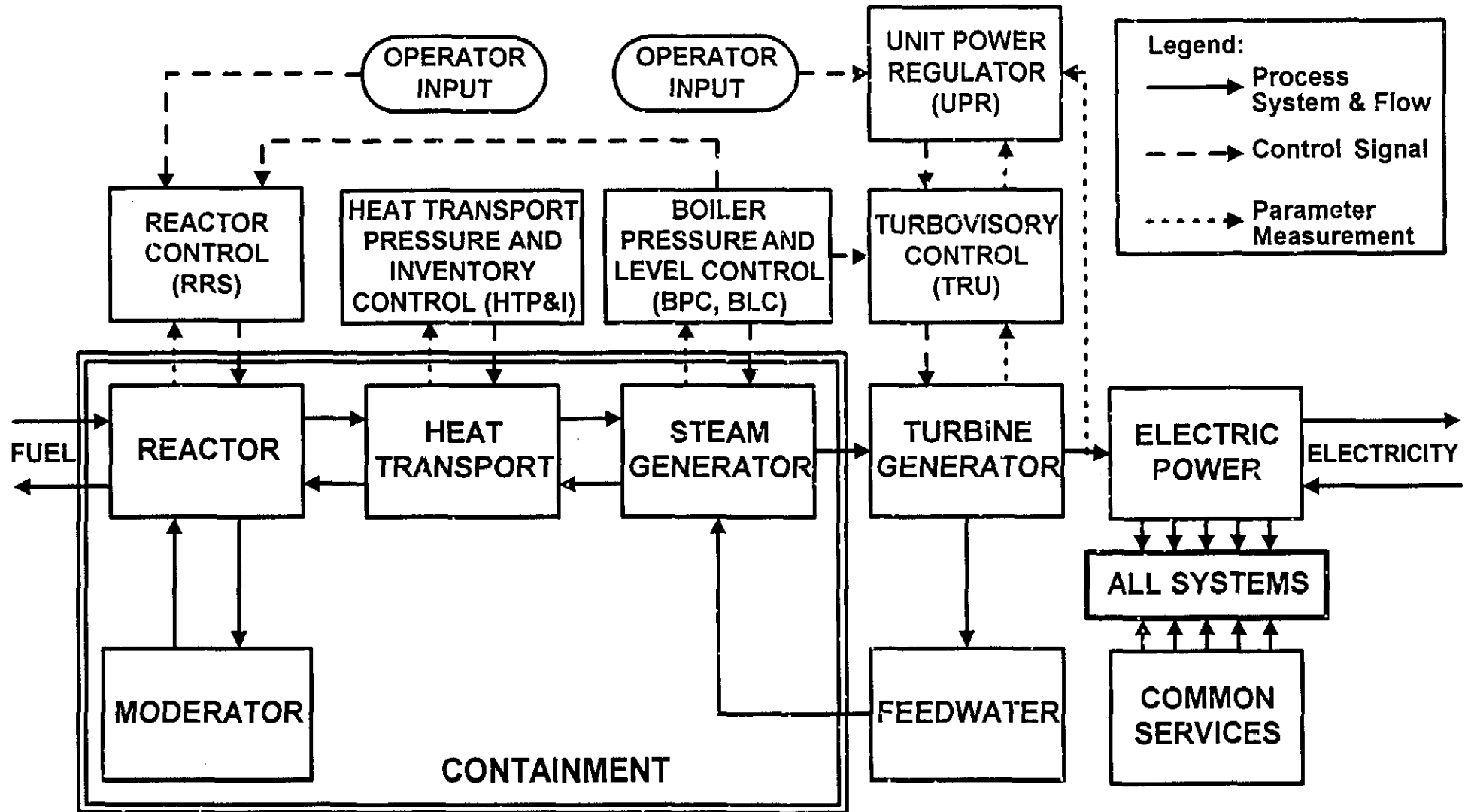


Figure 7: Simplified CANDU Main Process System Control Block Diagram



## 8. COMPUTERIZED STATION CONTROL SYSTEMS

Because of the complex interdependence of control systems in a CANDU unit, all major control functions are performed by Digital Control Computers (DCC). The main programs with the parameters measured and the different variables controlled and manipulated, are summarized in Table 1.

Table 1: Main CANDU Control Programs.

Program Name	Measured Parameter (s)	Variable(s) Controlled	Variable(s) Manipulated
1. Unit Power Regulator (UPR)	<ul style="list-style-type: none"> <li>Electrical output</li> </ul>	<ul style="list-style-type: none"> <li>Electrical output</li> <li>Steam flow</li> </ul>	<ul style="list-style-type: none"> <li>Steam flow</li> </ul>
2. Reactor Regulating System (RRS)	<ul style="list-style-type: none"> <li>Reactor bulk power</li> </ul>	<ul style="list-style-type: none"> <li>Neutron flux</li> </ul>	<ul style="list-style-type: none"> <li>Zone water level</li> <li>Rod position</li> </ul>
3. Heat Transport Pressure and Inventory Control (HTP&I)	<ul style="list-style-type: none"> <li>HTS Pressure</li> </ul>	<ul style="list-style-type: none"> <li>D<sub>2</sub>O pressure</li> <li>Pressurizer level</li> </ul>	<ul style="list-style-type: none"> <li>Pressurizer steam bleed &amp; heaters</li> <li>D<sub>2</sub>O feed &amp; bleed</li> </ul>
4. Boiler Pressure Control (BPC)	<ul style="list-style-type: none"> <li>Boiler pressure</li> <li>Reactor power</li> <li>Steam flow</li> </ul>	<ul style="list-style-type: none"> <li>Boiler pressure</li> </ul>	<ul style="list-style-type: none"> <li>Reactor setpoint</li> <li>Steam flow</li> </ul>
5. Boiler Level Control (BLC)	<ul style="list-style-type: none"> <li>Boiler level</li> <li>Reactor power</li> <li>Feedwater flow</li> <li>Steam flow</li> </ul>	<ul style="list-style-type: none"> <li>Level (inventory)</li> </ul>	<ul style="list-style-type: none"> <li>Feedwater flow</li> </ul>

## 9. CANDU 9 OPERATING CHARACTERISTICS

- The gross output of the generator is 925 MW and the station service power is 55 MW, yielding a net unit electrical output of 870 MW.
- The unit is capable of sustained operation at any net electrical output of up to 100 percent of rated full power output.
- The overall plant control is normally of the reactor-following-turbine type.
- The reactor and turbine are controlled by computer from zero to 100 percent of full power.
- For reactor power increases, the nuclear steam system portion of the plant is capable of maneuvering at the following rates:

Power Range	Maximum Rate
0 - 25 percent of full power	4 percent of actual power per second
25 - 80 percent of full power	1 percent of full power per second
80 - 100 percent of full power	0.15 percent of full power per second

- The overall plant power maneuvering rate is a function of turbine design, and is typically limited to 5 - 10% of full power per minute.

## **CHAPTER 1: OVERALL UNIT**

### **MODULE C: CANDU NUCLEAR SYSTEMS**

#### **MODULE OBJECTIVES:**

**At the end of this module, you will be able to describe the following for the Nuclear Systems of a CANDU generating station:**

- 1. The main functions and components of each major process and process support system;**
- 2. The main functions and components of each major control system;**
- 3. The key process, control and safety related interactions between the major systems**

## 1. CANDU NUCLEAR POWER PLANT MAIN SYSTEMS

- the three main groups of process systems are the
  - nuclear steam supply system
  - the steam utilization and turbine-generator system
  - the electric power system

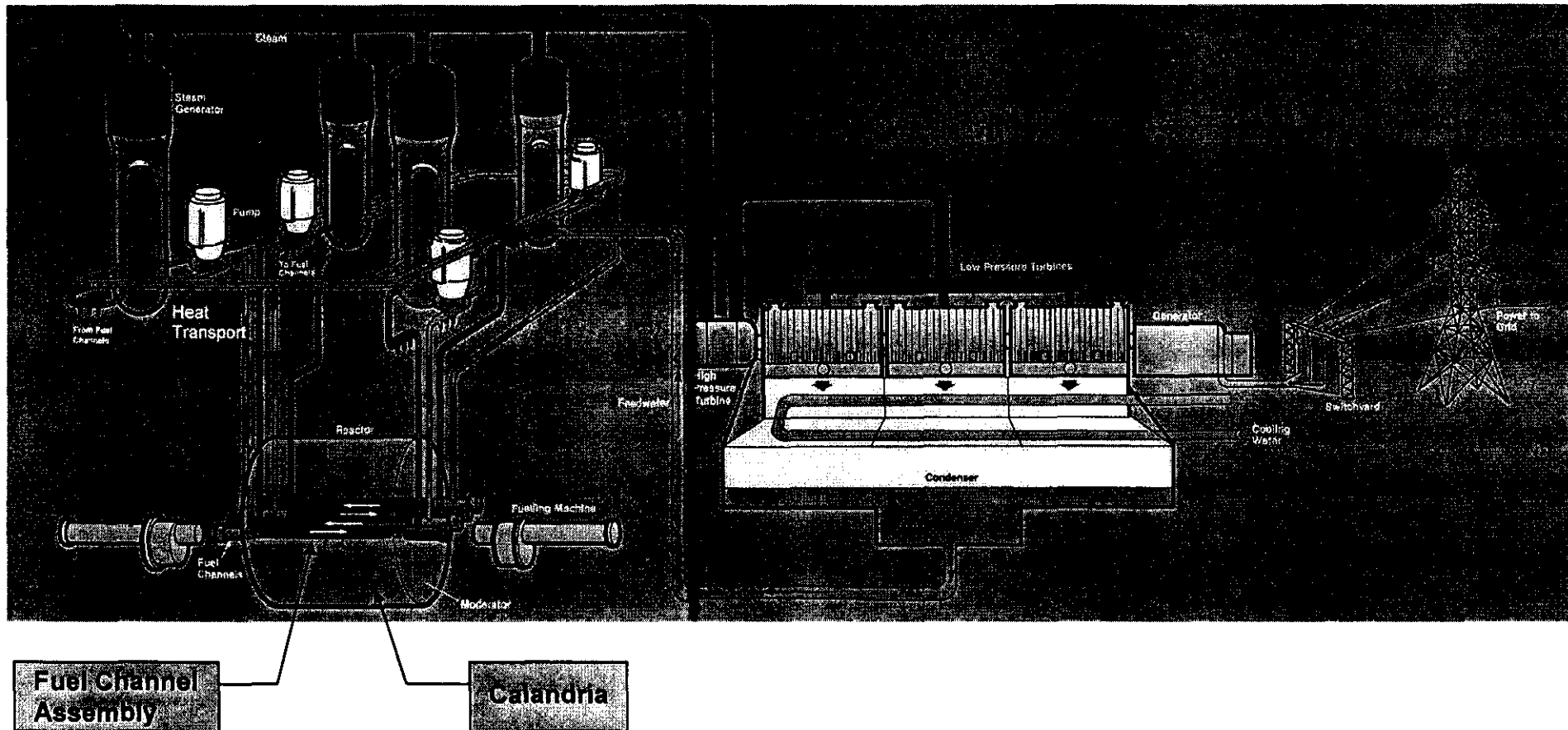


Figure 1: CANDU Nuclear Power Plant Main Process Systems

## **2. NUCLEAR STEAM SUPPLY SYSTEM**

- **the Reactor Assembly consists of**
  - **Calandria, which is a stainless steel horizontal cylindrical vessel that contains the heavy water moderator and reflector;**
  - **shield assembly of concrete and steel, containing light water;**
  - **hundreds (480 for CANDU 9) of fuel channel assemblies, each of which consists of a calandria tube that surrounds a pressure tube that contains 12 natural uranium fuel bundles and carries the pressurized heavy water heat transport coolant;**
  - **reactivity control units and neutron flux measuring devices;**
- **the Heat Transport System has**
  - **a main circuit, with four boilers, four circulating pumps, several headers and piping connections to each pressure tube;**
  - **pressure and inventory control system, shutdown & maintenance cooling, and several other systems;**
- **the Steam Generator System has the following main components:**
  - **the four steam generators, where the heat of the heavy water coolant boils light water to form steam;**
  - **the pressure of the boiler is controlled by altering the steam flow leaving the steam generator;**
  - **the water level in the boiler is controlled by altering the feedwater flow supply to the boiler.**

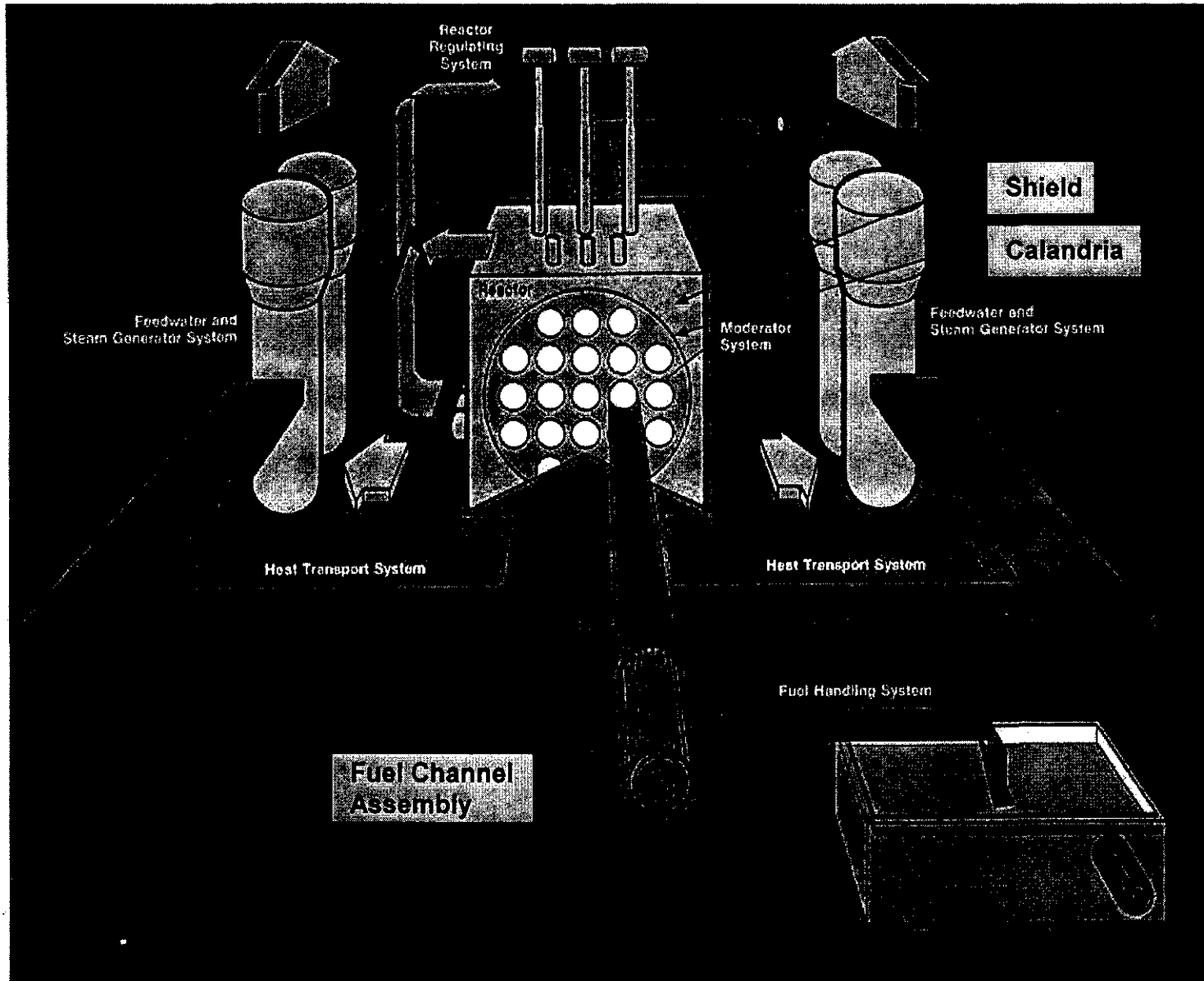
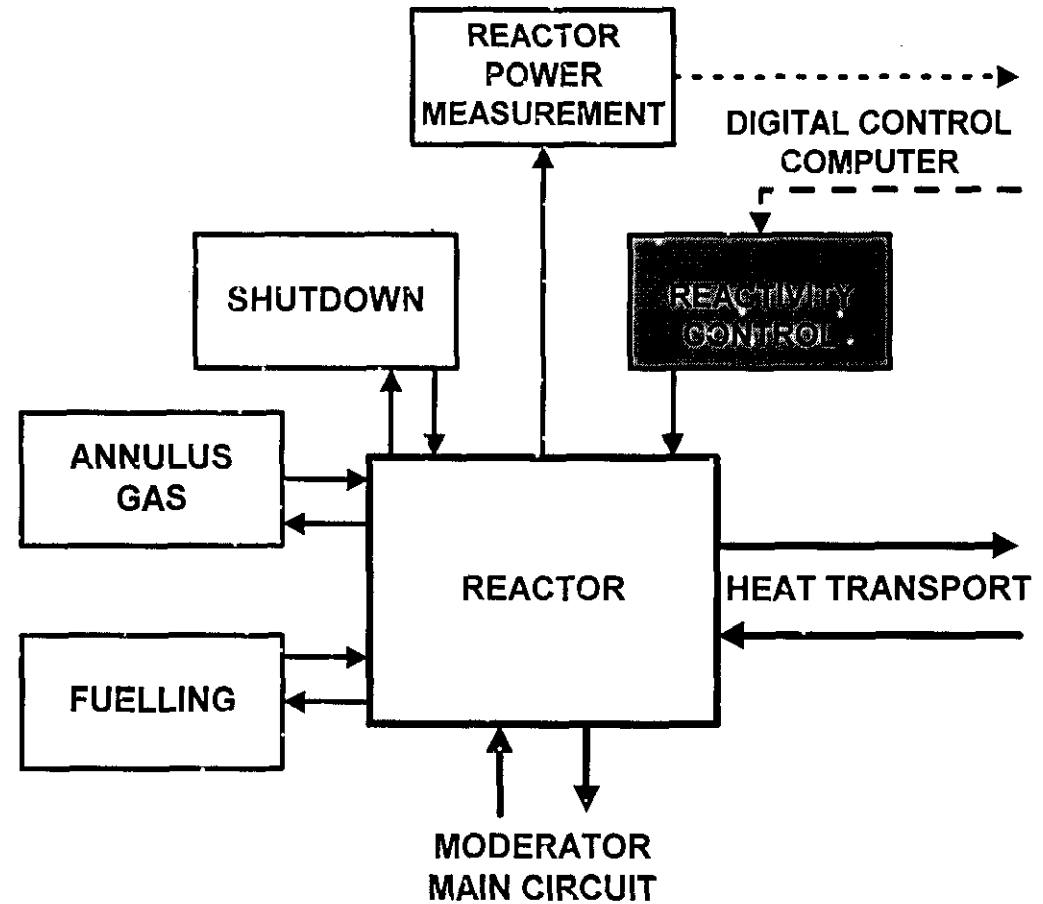


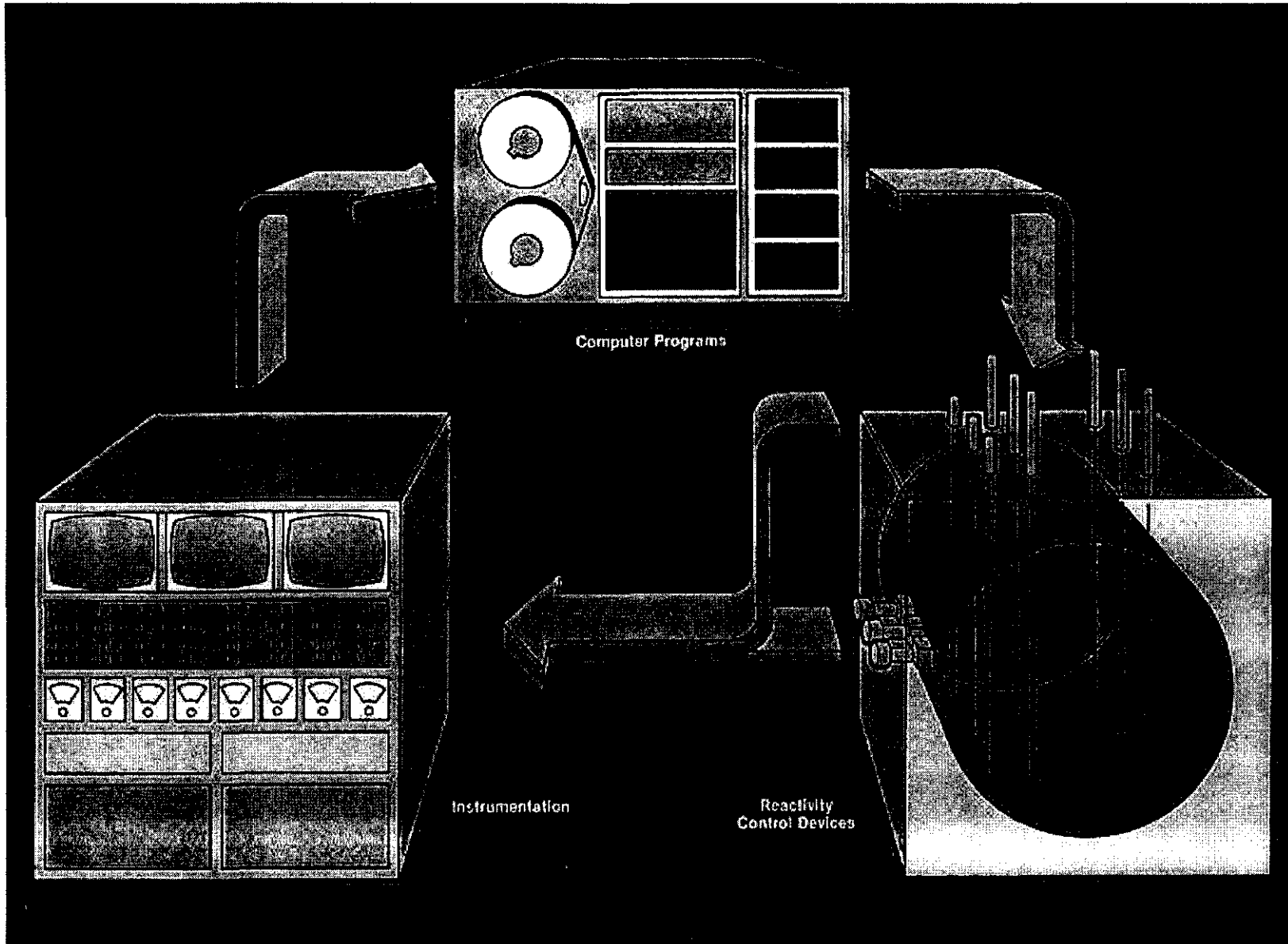
Figure 2: CANDU Nuclear Steam Supply System

### 3. REACTOR REGULATING SYSTEM

The Reactor Regulating System (RRS) controls reactor power so that:

- the power demanded by station load conditions or the operator are met
- power level and rates of change are within prescribed limits
- spatial power distribution in the reactor is within prescribed limits
- reactor power setpoint is determined by:
  - ⇒ UPR under 'normal' mode;
  - ⇒ the operator under 'alternate' mode;
  - ⇒ RRS under trip, stepback or setback conditions;
- RRS adjusts the reactivity mechanisms to eliminate the error between demanded and actual power;
- fine reactivity and spatial flux control is by adding or removing light water to/from compartments that are in the reactor core in the form of vertical zone control units;
- additional and course reactivity control is provided by:
  - ⇒ adjuster rods;
  - ⇒ mechanical control absorbers;
  - ⇒ soluble poison in the moderator;
- long term reactivity control is by semi-continuous on-power refueling.



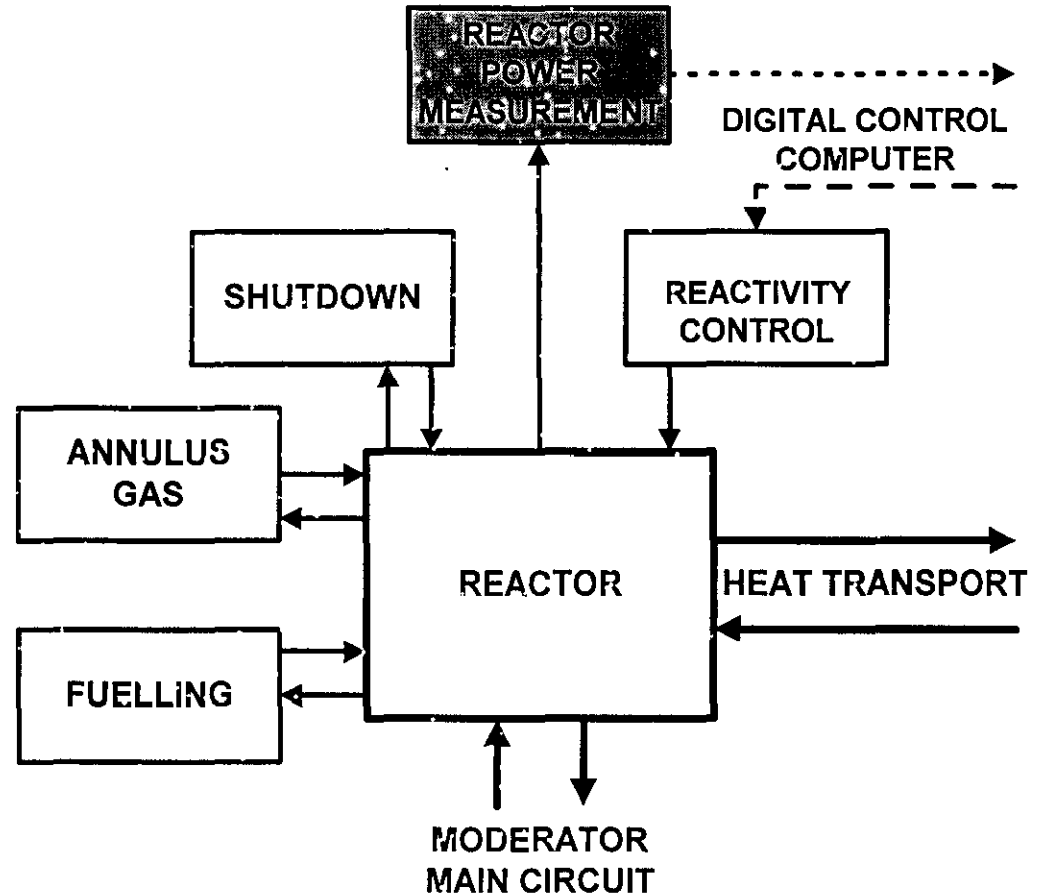


**Figure 3: Reactor Regulating System**



#### 4. REACTOR POWER MEASUREMENT

- ion chamber units mounted on the outside of the calandria shell provide the following measurements:
  - ⇒ log neutron power,  $10^{-7}$  to 150% full power;
  - ⇒ linear neutron power, 0 to 150% full power;
  - ⇒ rate of change of log power, -15% to +15% of present power per second;
- in-core flux detectors are distributed throughout the reactor core and provide the linear measurements of the local flux between 10% and 120% full power;
- both the ion chamber signals and the in-core flux detector signals must be calibrated by the use of thermal power measurements



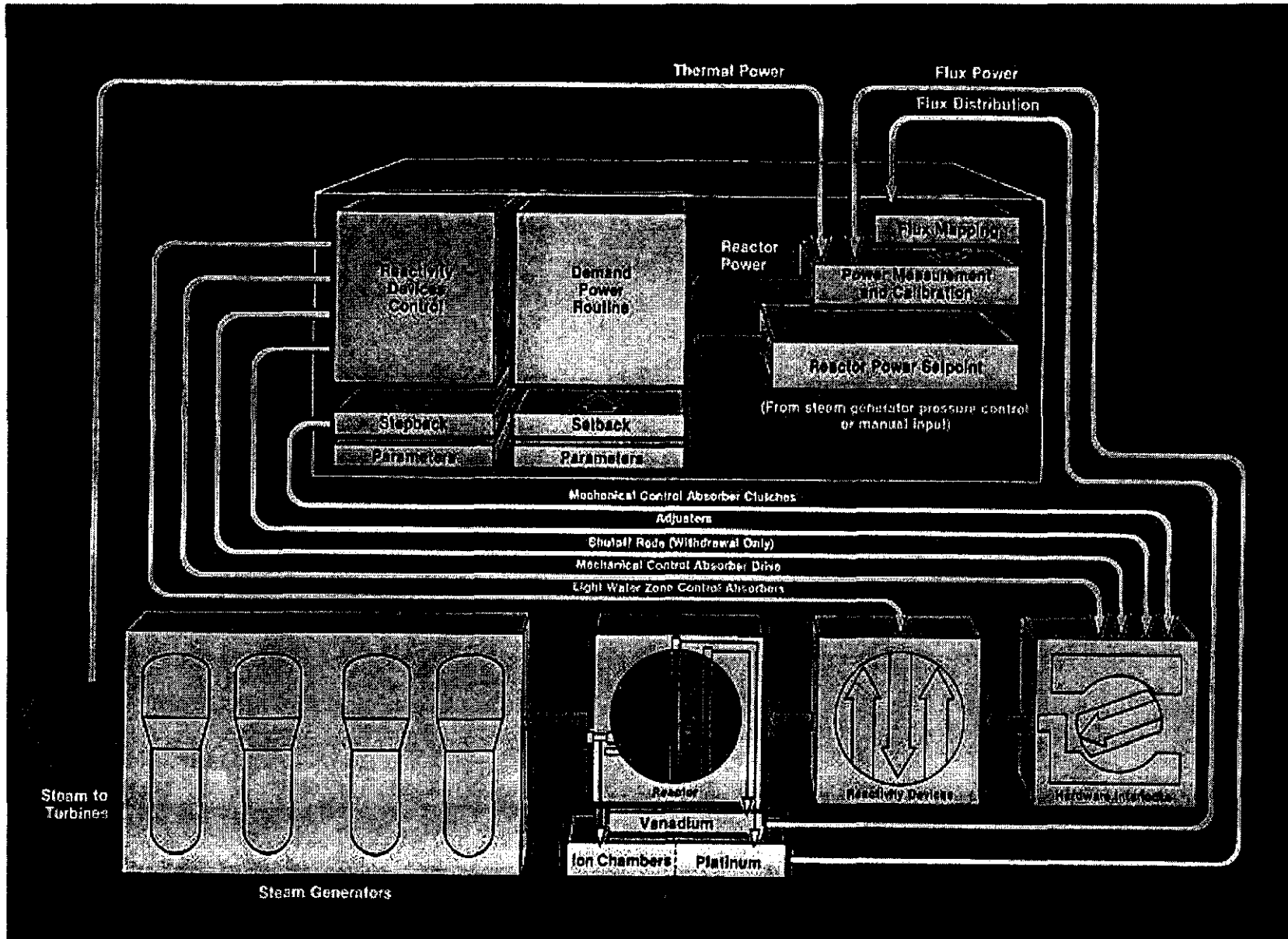


Figure 4: Reactor Power Measurement

## 5. REACTOR REGULATING SYSTEM COMPUTER PROGRAMS

- Flux Mapping and Power Measurement and Calibration programs compute accurate values of the bulk and spatial power distribution in the reactor;
- Demanded Power Routine uses the Actual Power Measurement and the Reactor Power Setpoint to:
  - ⇒ unit's operating mode ('normal' or 'alternate')
  - ⇒ the effective reactor power setpoint (demanded power)
  - ⇒ power error
- Setback routine monitors a number of plant parameters, and if these exceed preset values, it will reduce the reactor power setpoint at a rate and to a level that depends on the parameter that is outside its prescribed limit;
- Reactivity Devices Control program alters the level of the water in each of the liquid zones to shape the flux and to alter bulk reactor power to minimize the power error, as well as controlling the movement of the other reactivity control devices
- Stepback routine is able to reduce reactor power rapidly under conditions that mat otherwise lead to a reactor trip, by dropping the control absorber rods fully or partially into the reactor core

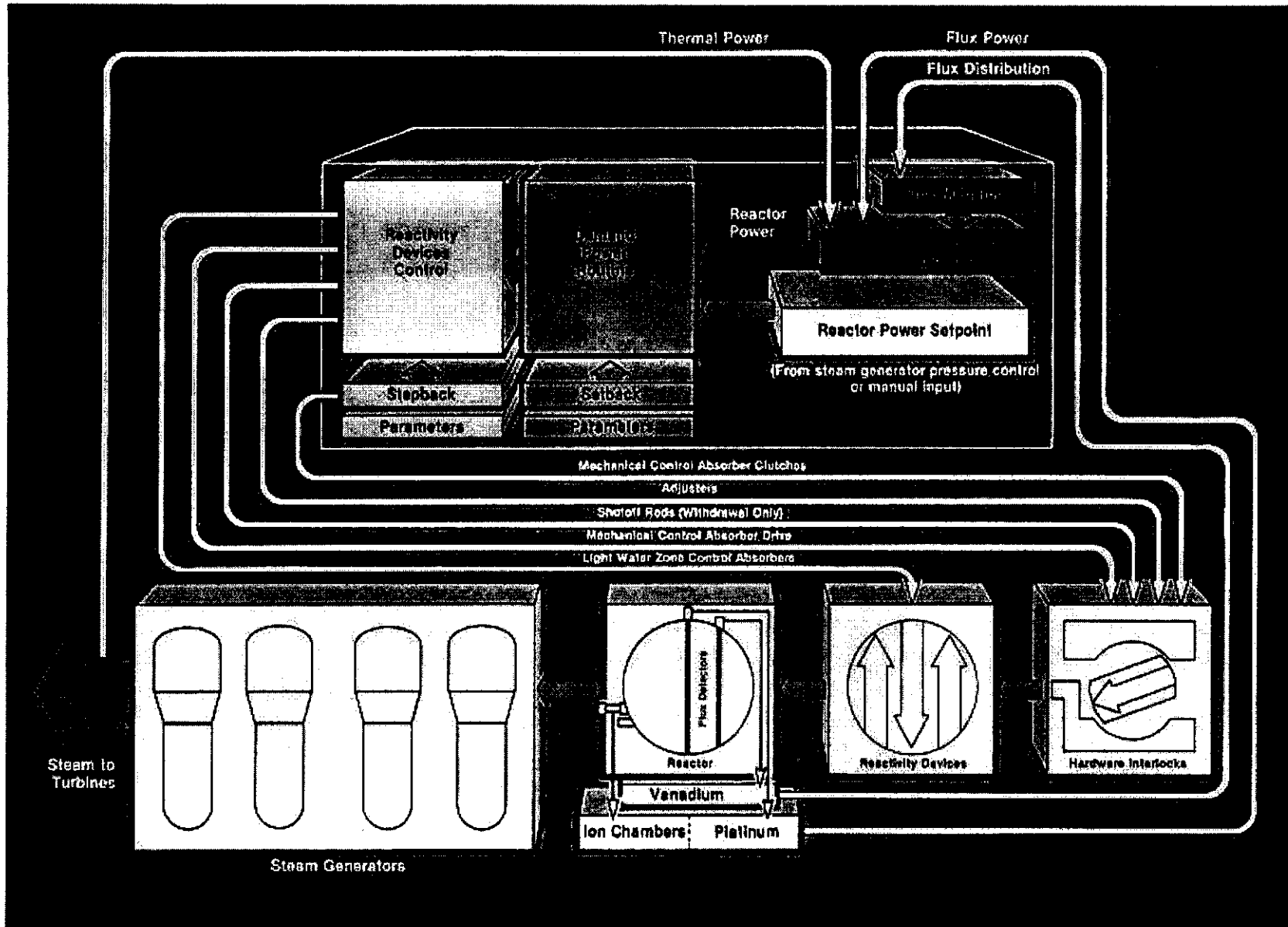
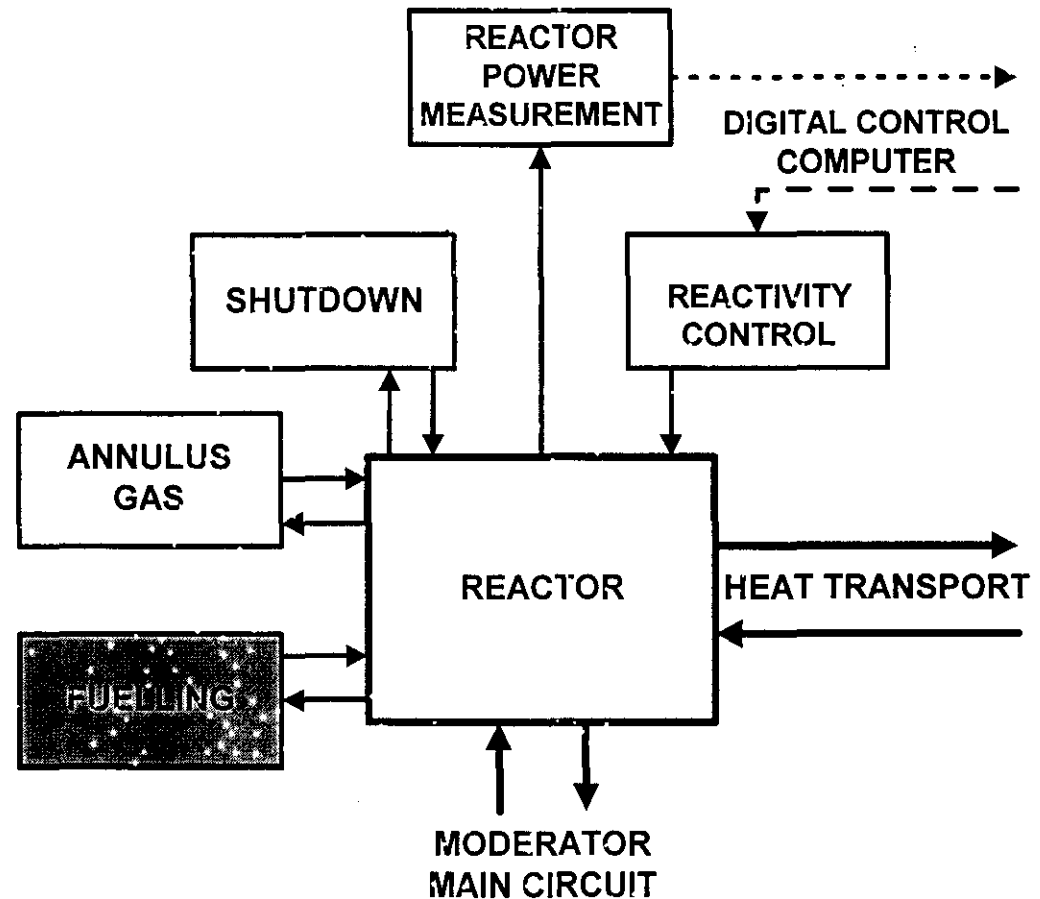


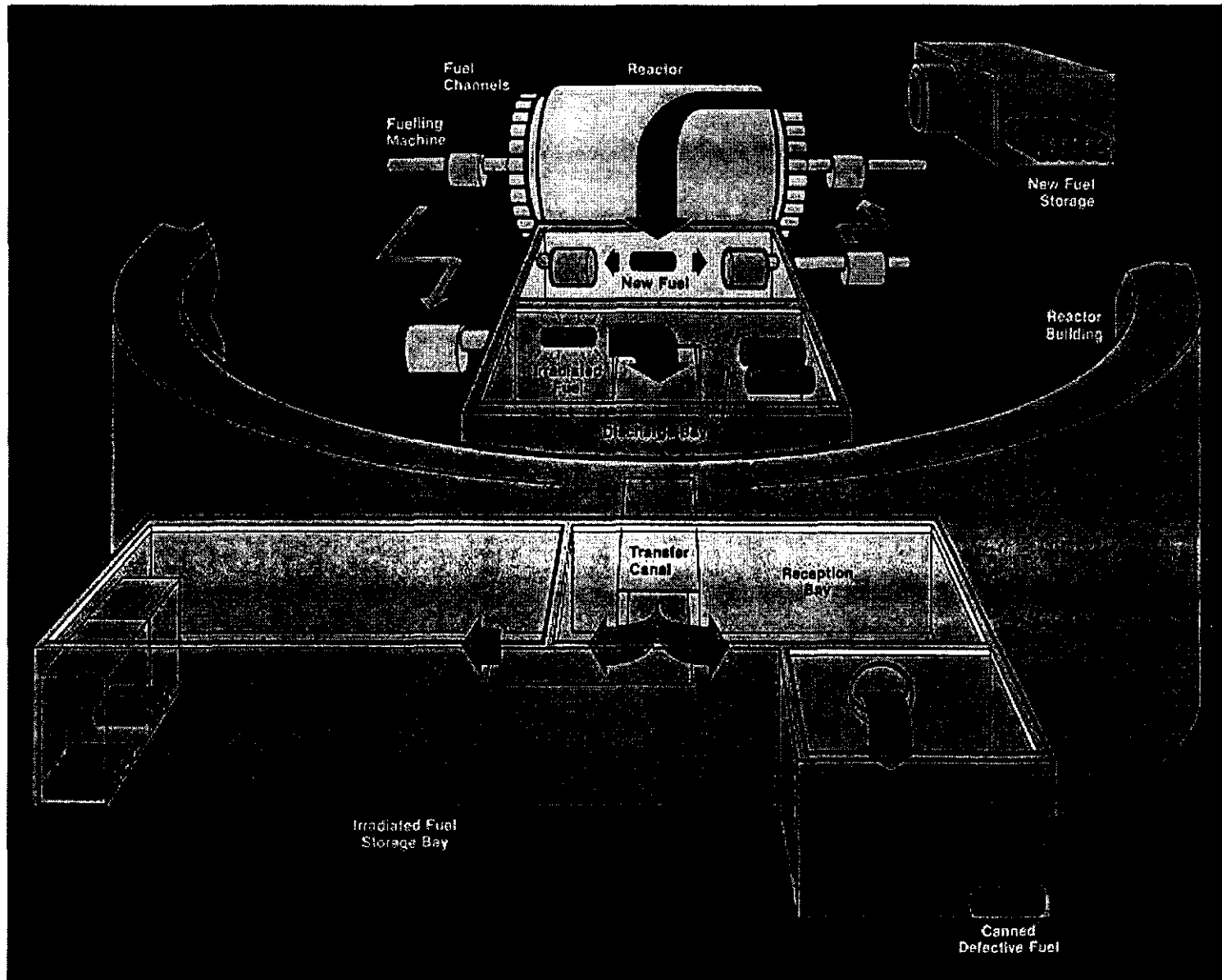
Figure 5: Reactor Regulating System Computer Programs

## 6. FUEL HANDLING AND STORAGE

Typical refueling operations require that each day eight fuel bundles are replaced in one or two channels. Facilities to support this operation include:

- receiving, storing and inspecting new fuel;
- loading of new fuel into fuelling machines;
- on-line removal of spent fuel and insertion of fresh fuel;
- transfer of irradiated fuel to storage bays;
- provision of fuel cooling during removal and transfer to prevent fuel failure;
- underwater storage of irradiated fuel until it can be transferred to dry storage (at least six years);
- apart from the loading of new fuel bundles into the magazines of the new fuel ports, all other operations are controlled remotely from the control room using digital computers.





**Figure 6: Fuel Handling and Storage**

## 7. MODERATOR SYSTEMS

- main functions are to remove the heat generated in the moderator during reactor operation and to control the level of the moderator in the calandria (normally full);
- pumps circulate the heavy water moderator through the calandria and the heat exchangers;
- pressures and temperatures are only slightly above atmospheric;
- provides a heat sink in case of loss of coolant accident involving broken pressure and calandria tubes;
- provides a means of reactivity control by the amount of poison dissolved in the moderator;
- provides a means of rapid reactor shutdown by injection of poison into the moderator;
- provides a means of guarantying reactor shutdown by dissolving excess poison into the moderator, or draining the moderator from the calandria.

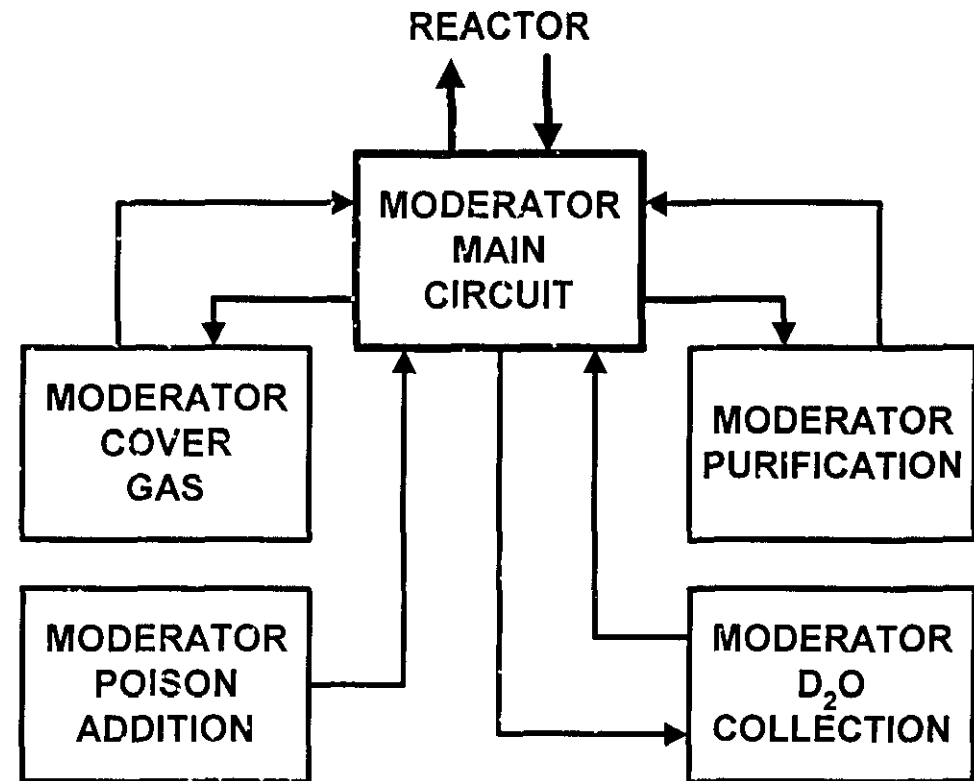
### 7.1 MODERATOR COVER GAS

- maintains a Helium gas cover over the moderator;
- prevents corrosion and reduces radioactivity;
- prevents accumulation of explosive concentrations of D<sub>2</sub>O gas.

### 7.2 MODERATOR LIQUID POISON

### 7.3 MODERATOR PURIFICATION

### 7.4 MODERATOR D<sub>2</sub>O COLLECTION



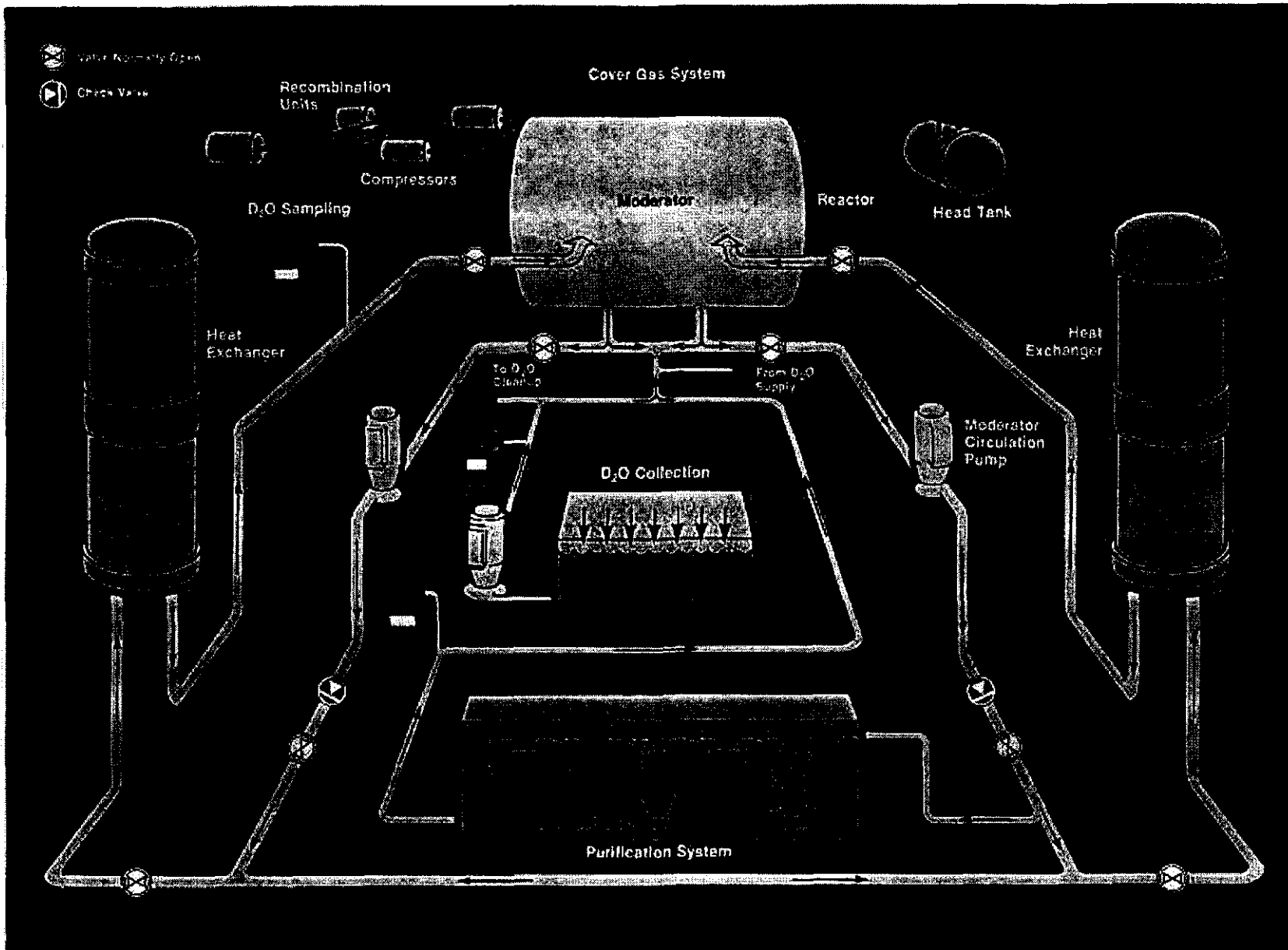
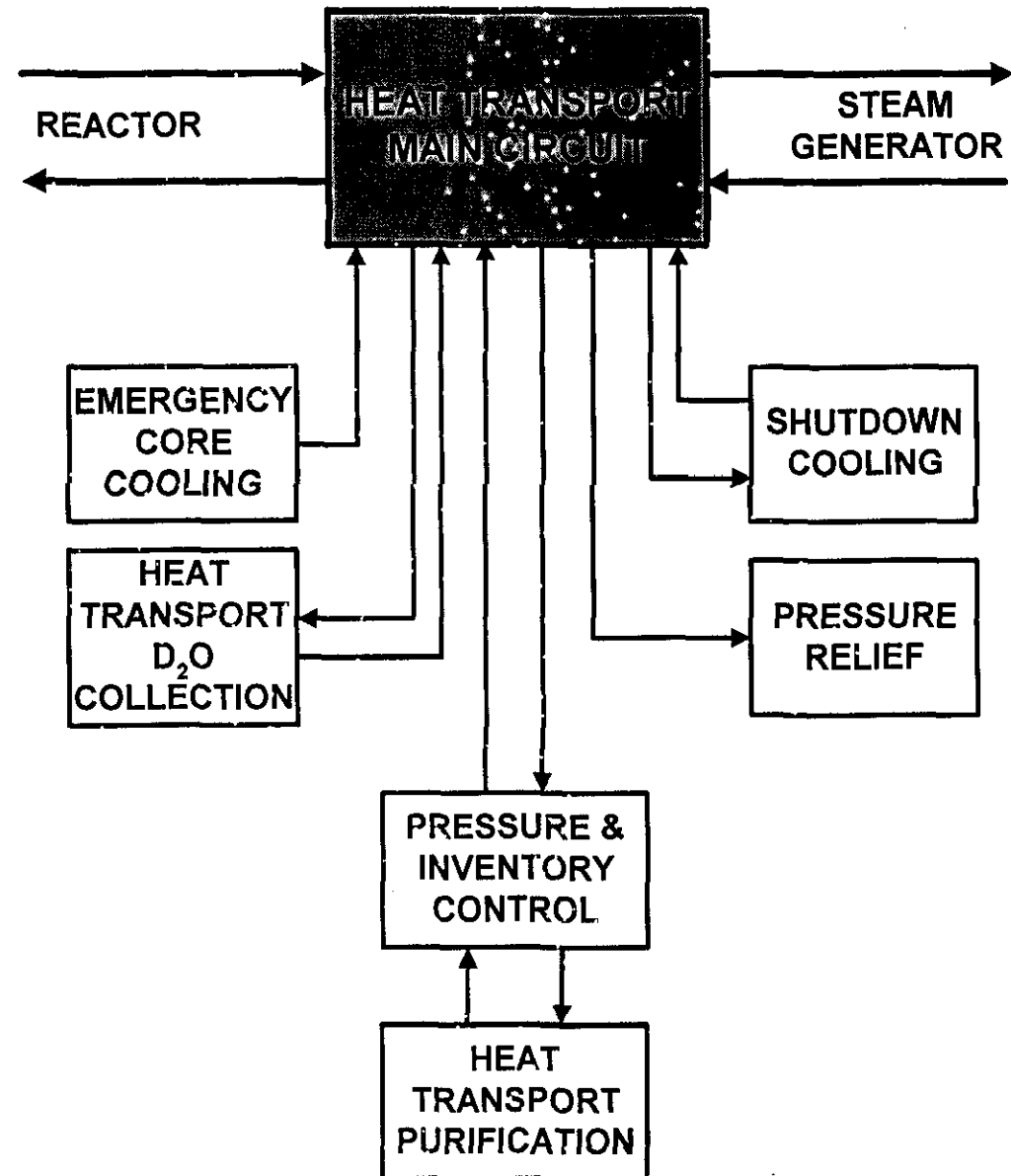


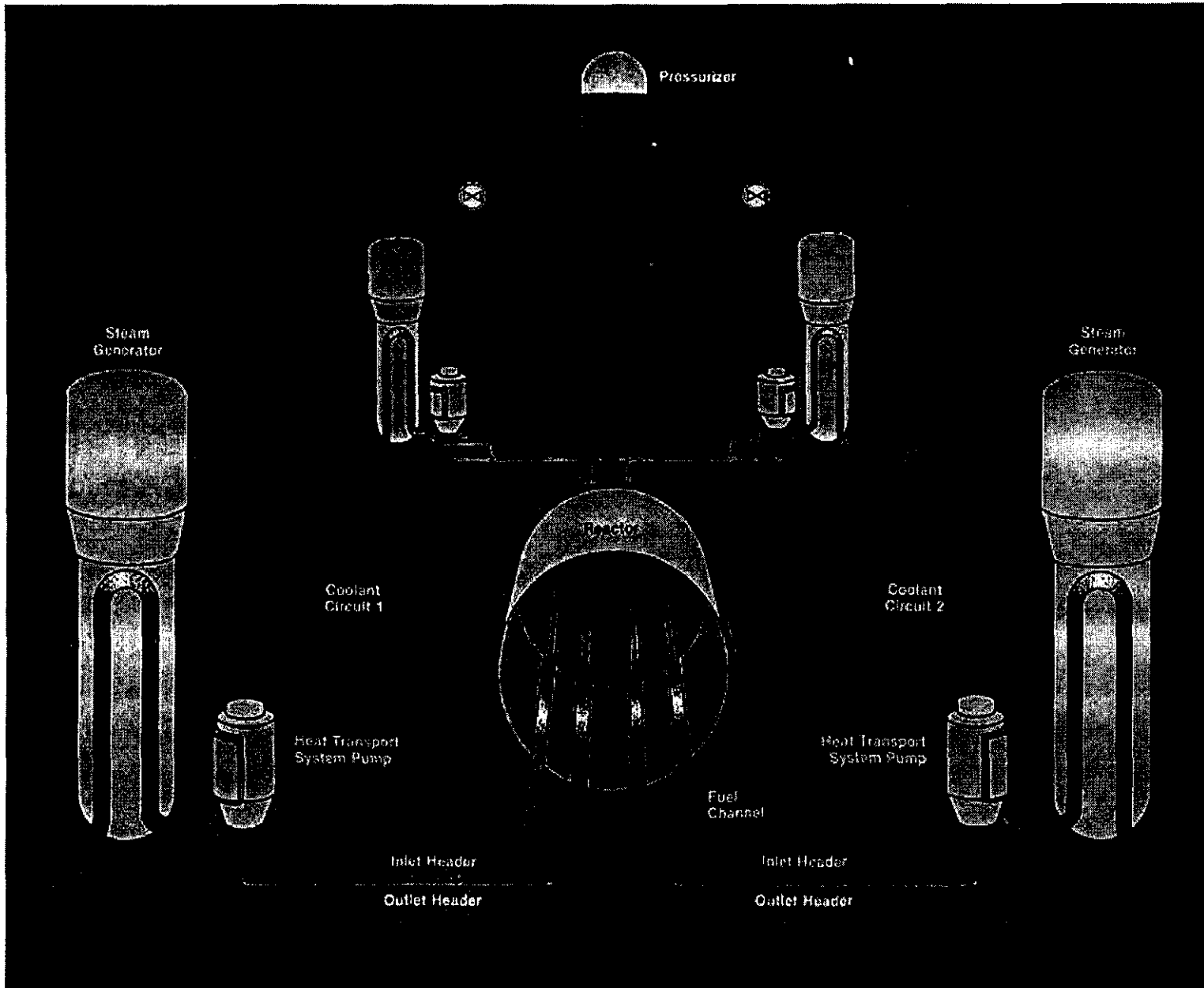
Figure 7: Moderator System



## 8. HEAT TRANSPORT SYSTEM

- uses pressurized heavy water to transfer heat from the reactor to the boilers;
- provides for the continuous cooling of the fuel;
- contains any fission products released from the fuel;
- consists of two loops with a figure of eight coolant flow pattern;
- bi-directional coolant flow through the core;
- reactor inlet and outlet headers connect the fuel channels through feeder pipes to the rest of the main circuit;
- has four steam generators of the vertical U-tube type with an integral preheating section;
- the four heat transport system pumps are vertical single discharge, electric motor driven, centrifugal pumps with multi-stage mechanical shaft seals;
- pressurizer maintains the required system pressure under normal operating conditions;
- no chemicals are added to the heat transport system for reactivity control.





**Figure 8: Heat Transport System**

## 9. PRESSURE AND INVENTORY CONTROL

- steam in a pressurizer is main means of pressure control;
- feed and bleed system provides inventory control, and is an alternate method of pressure control;
- keeps main circuit filled under normal operating conditions;
- provides over-pressure relief;
- cools the heavy water to allow its purification and storage.

### 9.1 PURIFICATION

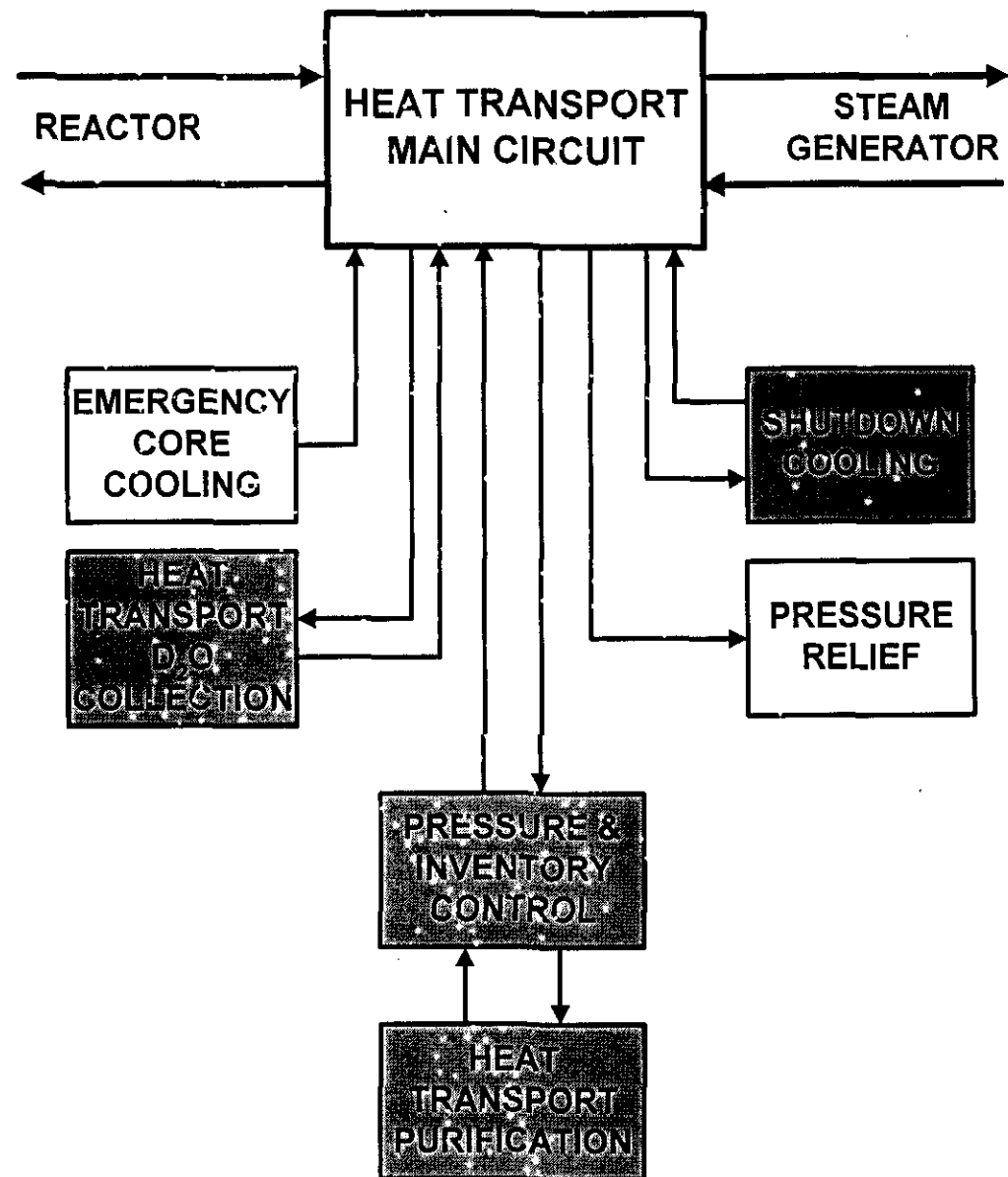
- limits the accumulation of corrosion products and other fine solids in the coolant;
- maintains the pD of the D<sub>2</sub>O at the required value.

### 9.2 SHUTDOWN COOLING

- cools the heat transport system below what possible by the boilers (<177°C)
- main components are heat exchangers, pumps and valves.

### 9.3 HEAT TRANSPORT COLLECTION

- provides routine collection of heavy water that escapes the heat transport system.



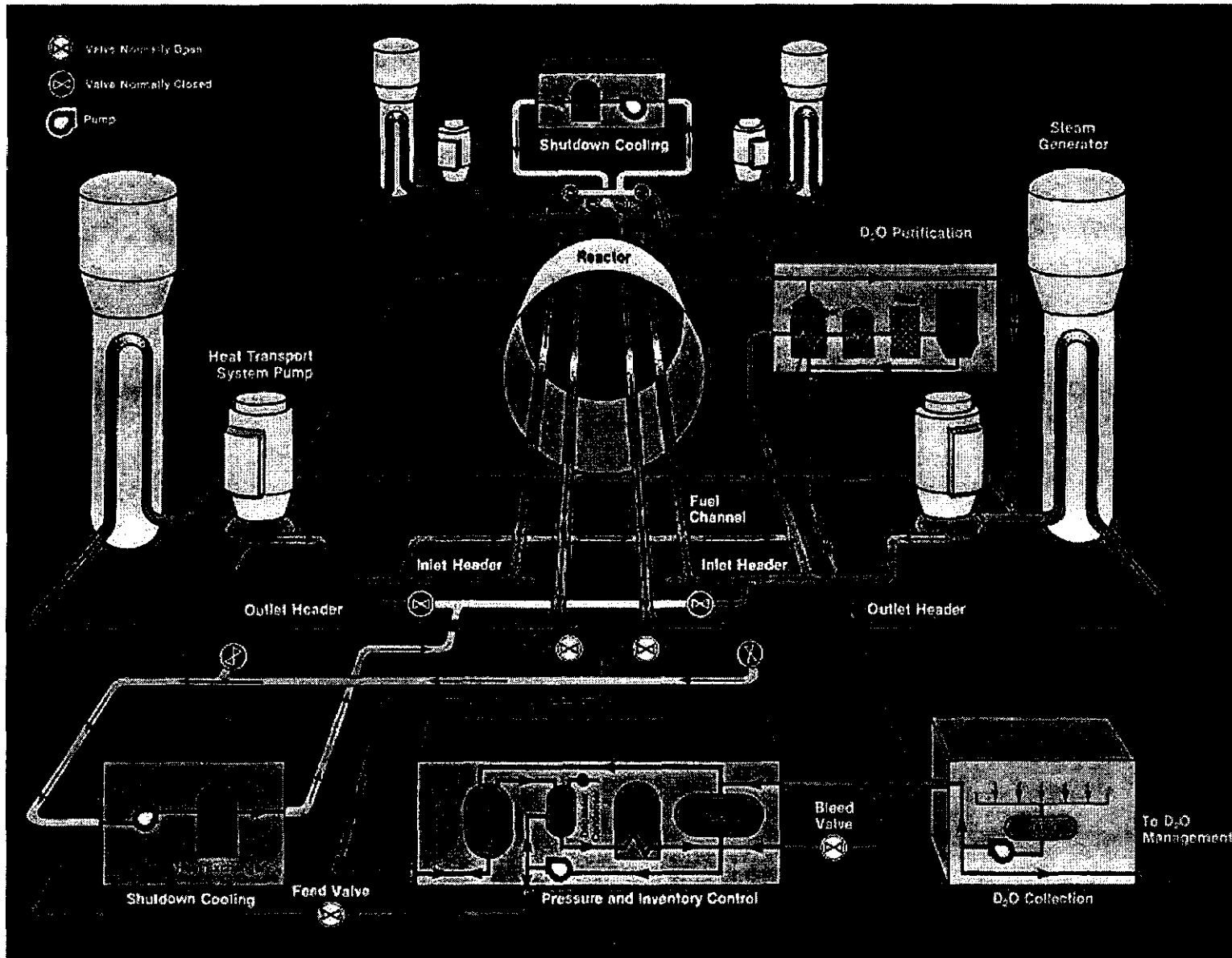


Figure 9: Pressure and Inventory Control System

## 10. STEAM GENERATOR, MAIN STEAM AND FEEDWATER SYSTEMS

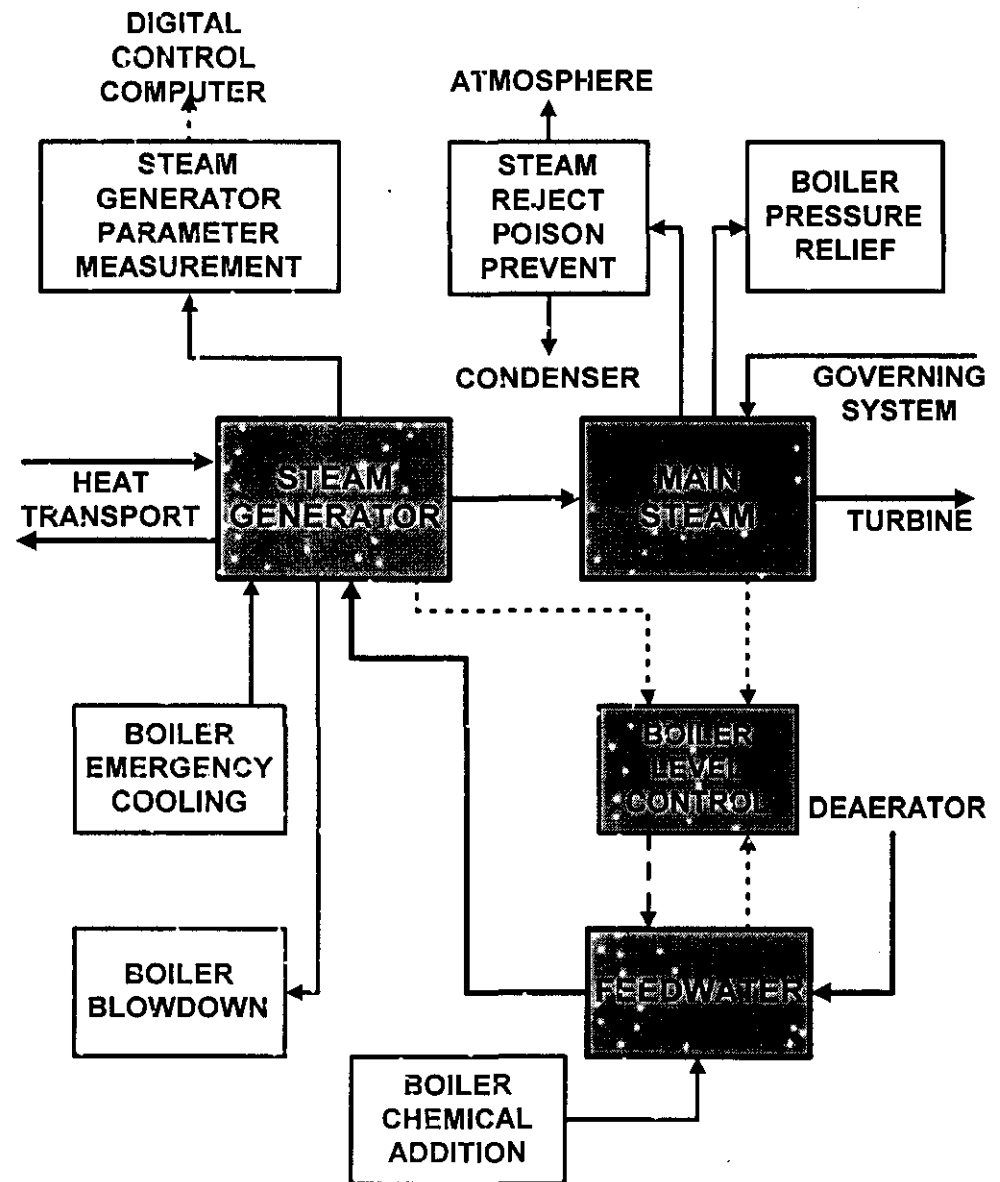
- the heavy water reactor coolant of the heat transport system flows through hundreds of small inverted 'U' tube bundles in each of the four steam generators and transfers heat to the light water contained in the steam generators.

### 10.1 MAIN STEAM

- the steam from the boilers is fed by separate steam mains to the turbine steam chest via the turbine stop valves, and its flow is controlled by the governor valves;
- when the turbine cannot accept the full steam flow the excess steam can be discharged to the atmosphere or bypass the turbine by flowing directly to the condenser;
- over-pressure protection is provided by four safety relief valves on each steam main.

### 10.2 FEEDWATER

- the feedwater system supplies demineralized and preheated light water to the steam generators;
- boiler level control is achieved by varying feedwater flow to the boilers based on measurements of steam and feedwater flow, and boiler level.



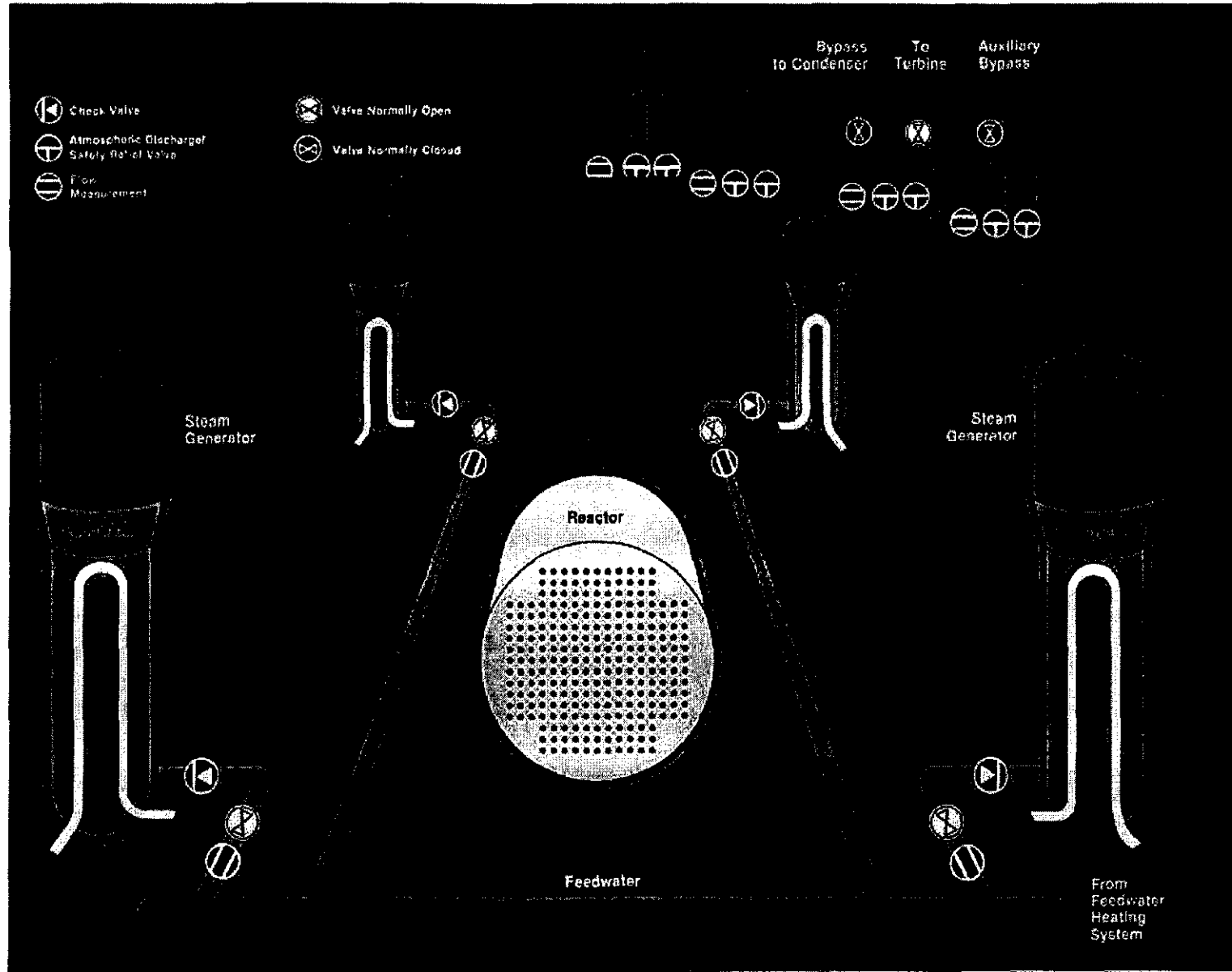


Figure 10: Steam Generator, Main Steam and Feedwater Systems

## **CHAPTER 1: OVERALL UNIT**

### **MODULE D: CANDU BALANCE OF PLANT, I&C AND SAFETY SYSTEMS**

#### **MODULE OBJECTIVES:**

At the end of this module, you will be able to describe the following for the Balance of Plant Systems of a CANDU generating station:

1. The main functions and components of each major process and process support system;
2. The main functions and components of each major control system;
3. The key process, control and safety related interactions between the major systems

## 1. TURBINE, GENERATOR, CONDENSATE AND FEEDHEATING SYSTEMS

all existing CANDU generating stations have turbine assemblies that consists of tandem compound units, with one double flow high pressure cylinder, and three double flow low pressure cylinders with external moisture separators and live steam reheaters between the high and low pressure stages

- the Governing system controls the turbine's speed of rotation when the generator is not synchronized to the grid, otherwise the governing system determines turbine/generator power;

### 1.1 GENERATOR

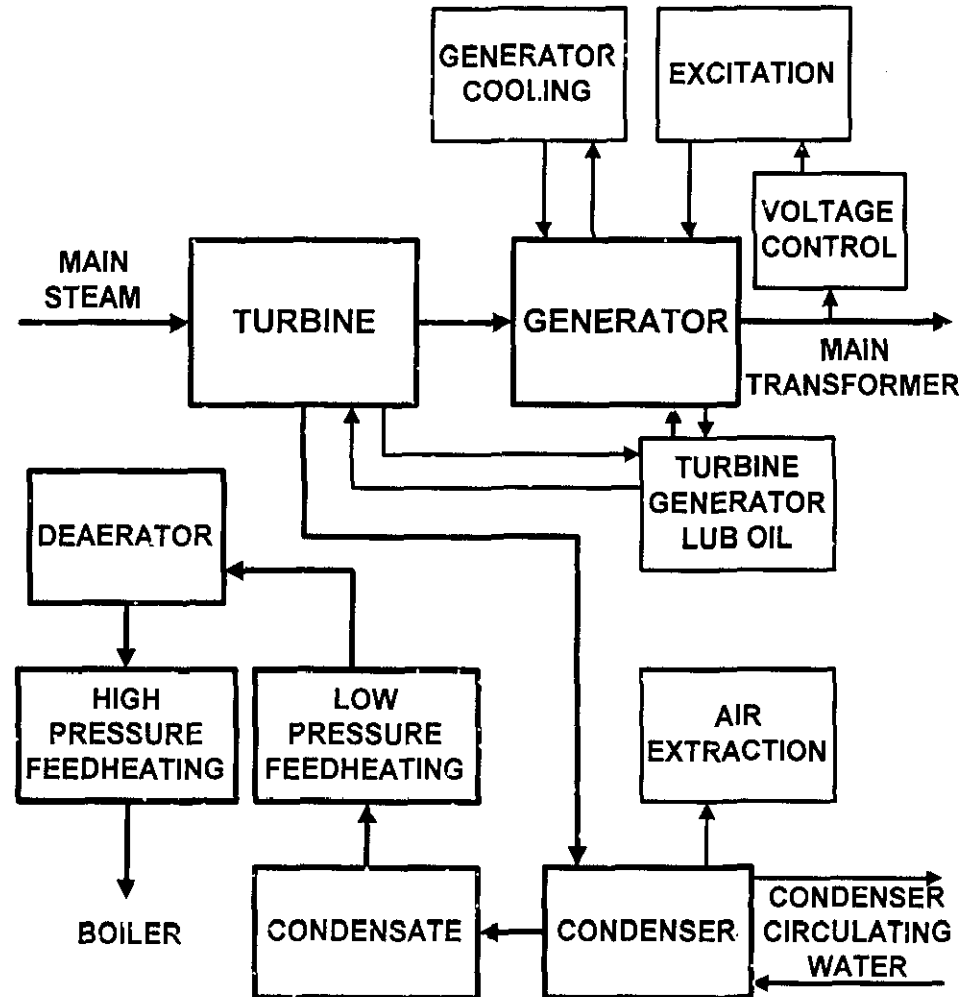
- three phase four pole machine directly coupled to the turbine;
- output voltage (usually) 24,000 volts;
- cooling of the rotor winding and stator core is by hydrogen, and of the stator winding by water.

### 1.2 CONDENSER

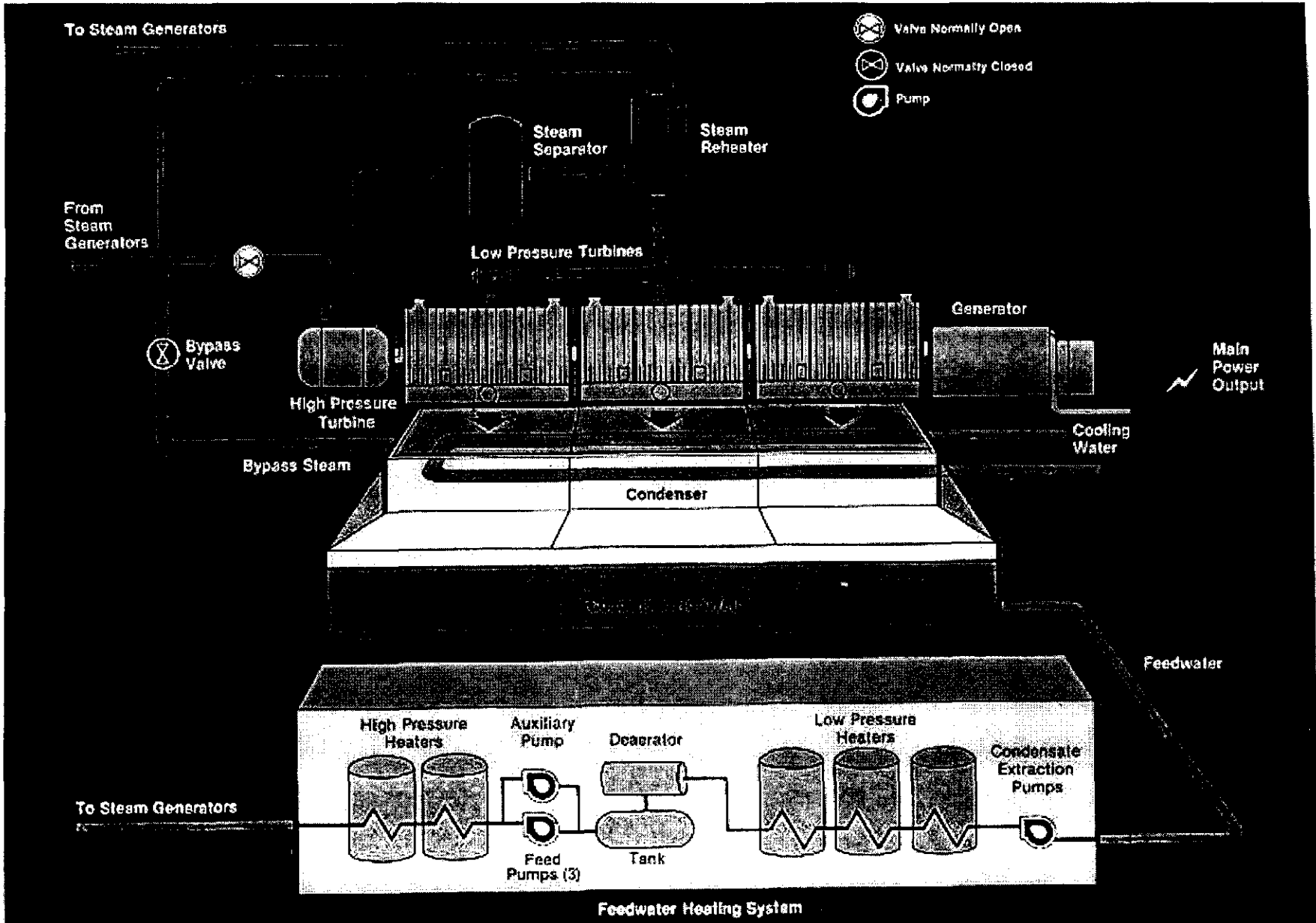
- consists of three separate shells, one for each low pressure turbine cylinder;
- can handle full steam by-pass flow when the turbine is not available.

### 1.3 FEEDHEATING

- uses extraction steam to preheat the feedwater in order to optimize thermodynamic efficiency;
- consists of three low pressure (LP), a deaerator, and two HP heaters;
- feed pumps return the feedwater to the boilers.



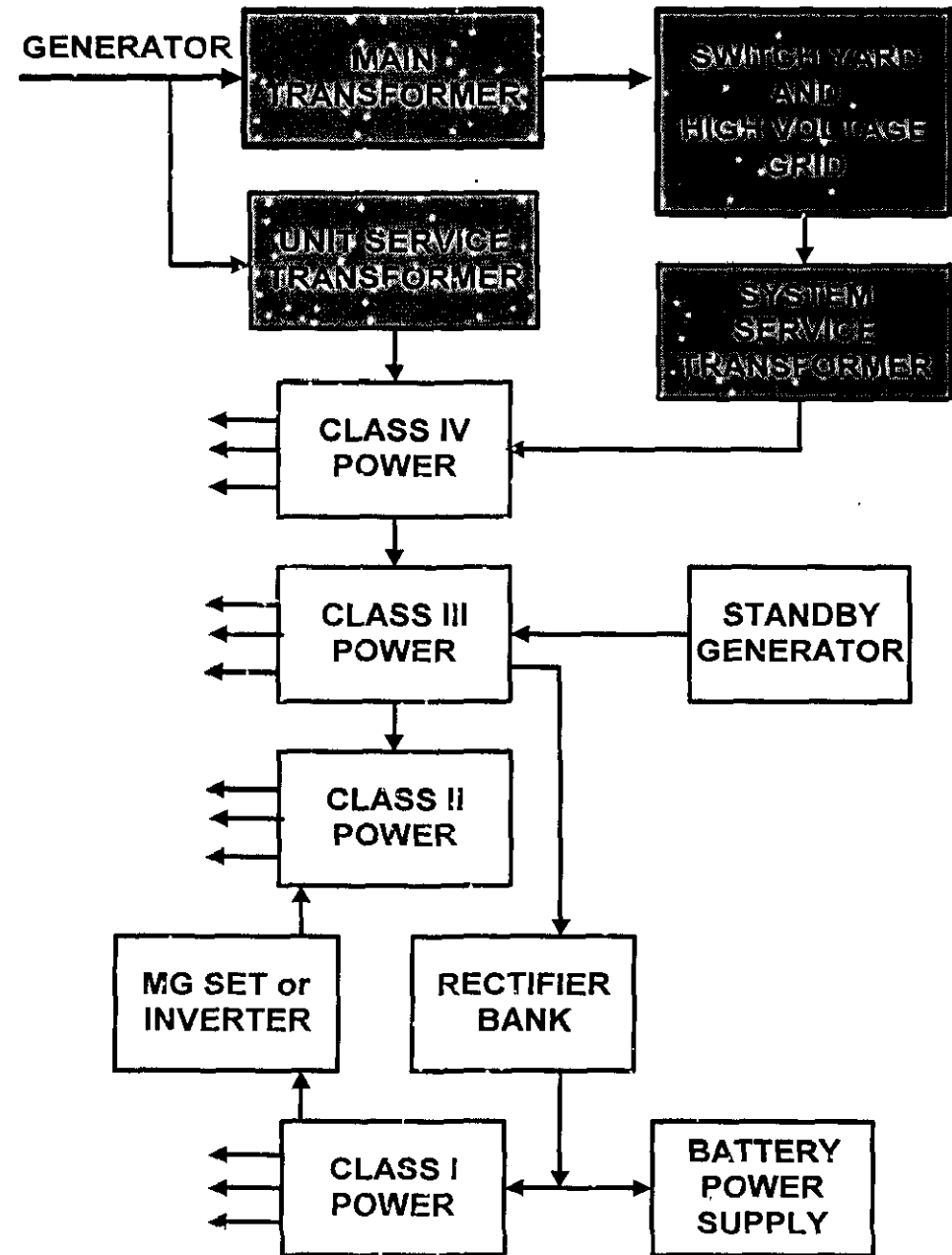


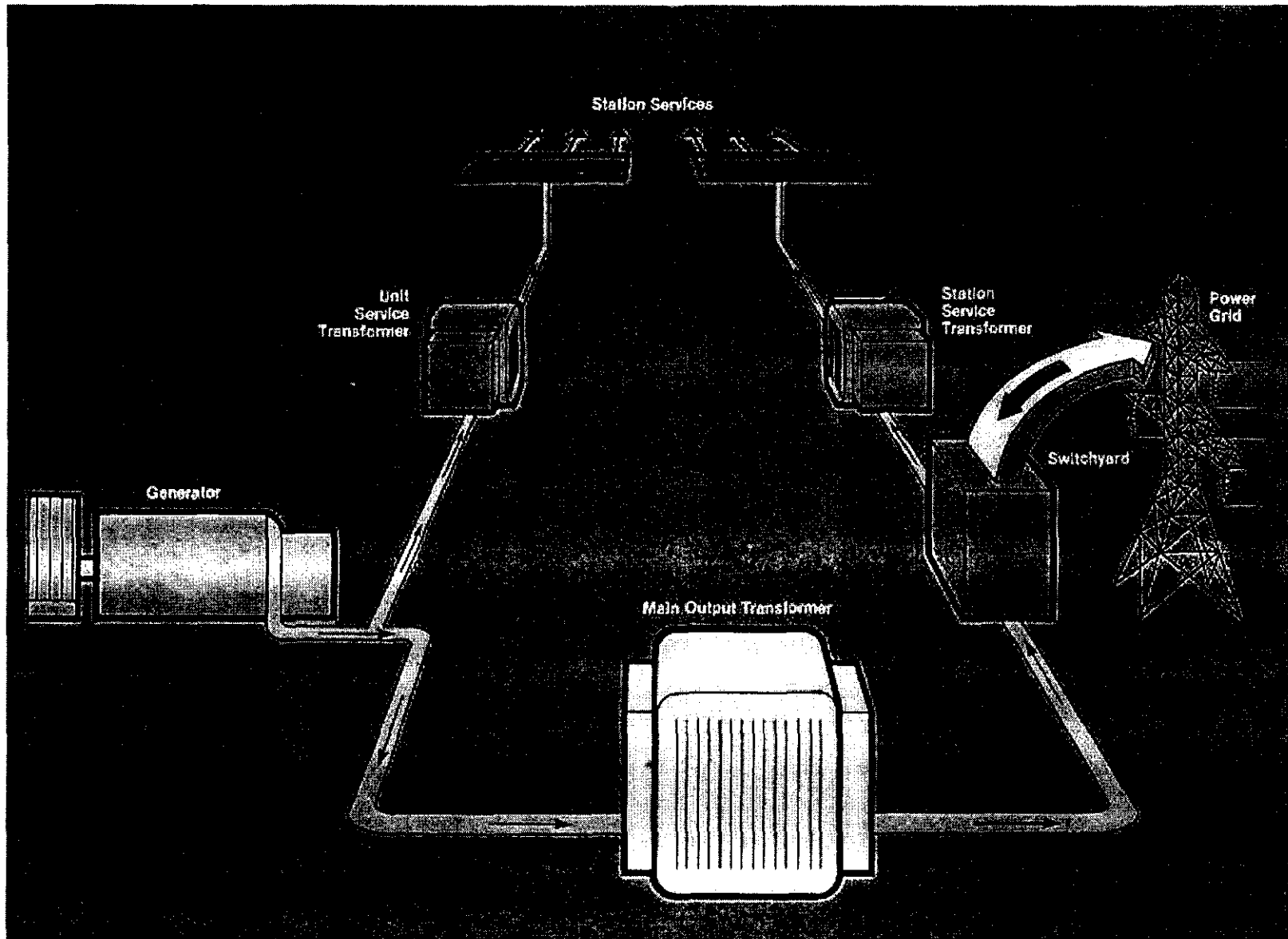


**Figure 1: TURBINE, GENERATOR, CONDENSATE AND FEEDHEATING SYSTEMS**

## 2. ELECTRIC POWER SYSTEM

- the output of the generator is stepped up in voltage by the Main Output and Unit Service transformers;
- the switchyard contains the breakers and disconnect switches which interconnect the station and the grid, and have automatic control to ensure the safe flow of electric power;
- unit service power is normally provided by the two 100 percent capacity transformers, the Unit Service transformer and the System Service transformer; an automatic transfer system ensures continuity of supply as long as one of the high voltage supplies are available;
- the unit service power is distributed and further stepped down in voltage as required.





**Figure 2: Electric Power Output System**

### 3. UNIT ELECTRIC POWER SERVICES

The power supplies are classified in terms of their level of reliability.

#### 3.1 Class IV Power

- supplies all major loads directly and all station equipment under normal operating conditions via the other classes;
- may be unavailable for extended periods (hrs);
- highest distribution voltage within the station (4 kV to 14 kV AC).

#### 3.2 Class III Power

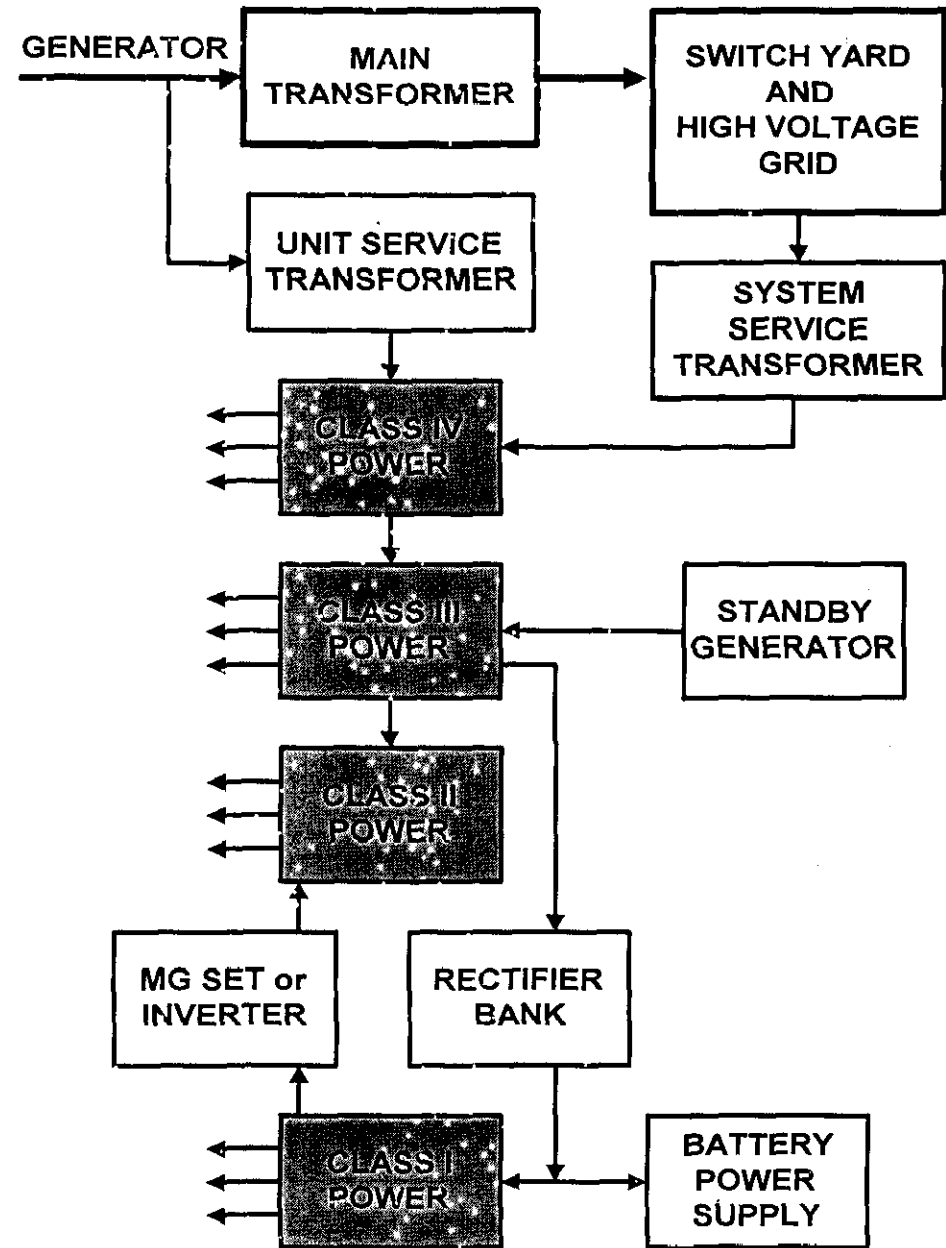
- supplies all loads necessary for safe shutdown of reactor and turbine;
- supplied by on-site Standby Generators if cannot be supplied from Class IV;
- may be unavailable for 3 minutes;
- typically 400 V to 5 kV AC.

#### 3.3 Class II Power

- supplies equipment and instrumentation essential to safe station operation;
- uninterruptible, supplied from batteries via Class I when cannot be supplied from Class III;
- typically 50 V to 250 V AC.

#### 3.4 Class I Power

- uninterruptible supply for all essential equipment;
- typically 50V to 250 V DC.



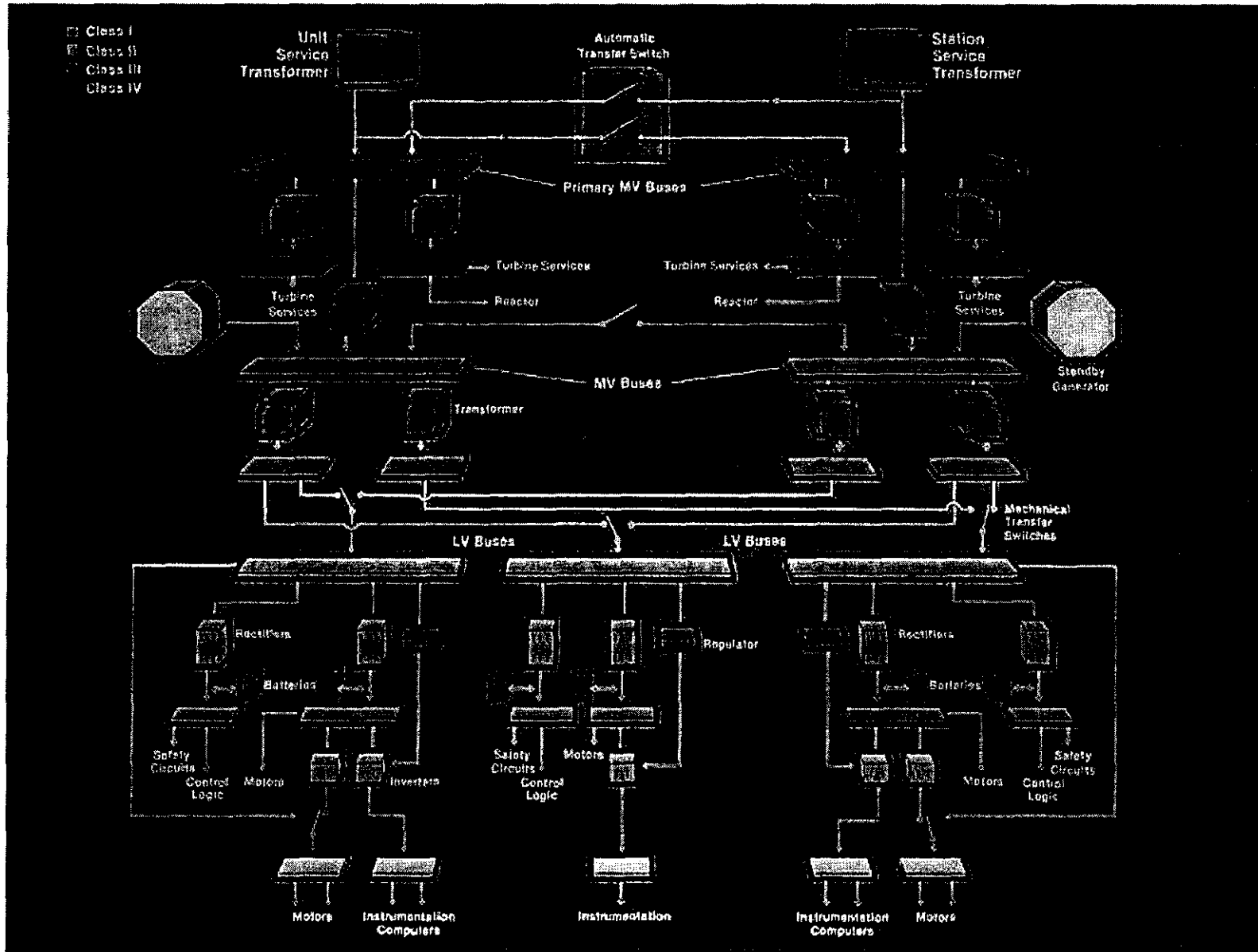


Figure 3: Unit Electric Power Distribution Systems

#### **4. INSTRUMENTATION AND CONTROL**

- **digital computers are used for station control, alarm annunciation, graphical data display and logging;**
- **there are two independent computers, both normally running, but each capable of controlling the unit;**
- **only the 'controlling' computer's outputs are connected to the field devices;**
- **a fault in any essential part of one computer results in automatic transfer of control to the other computer;**
- **if both computers fail the unit is automatically shut down;**
- **alarm messages are presented on two colour monitors, and line printers provide a chronological record of all alarm conditions;**
- **operator communication stations consist of a colour monitor and keyboard, and are the prime means by which the operator monitors and controls the unit;**
- **all major process systems are controlled by the dual redundant computer system;**
- **the safety systems use triplicated instrumentation, and are independent of the control computers.**

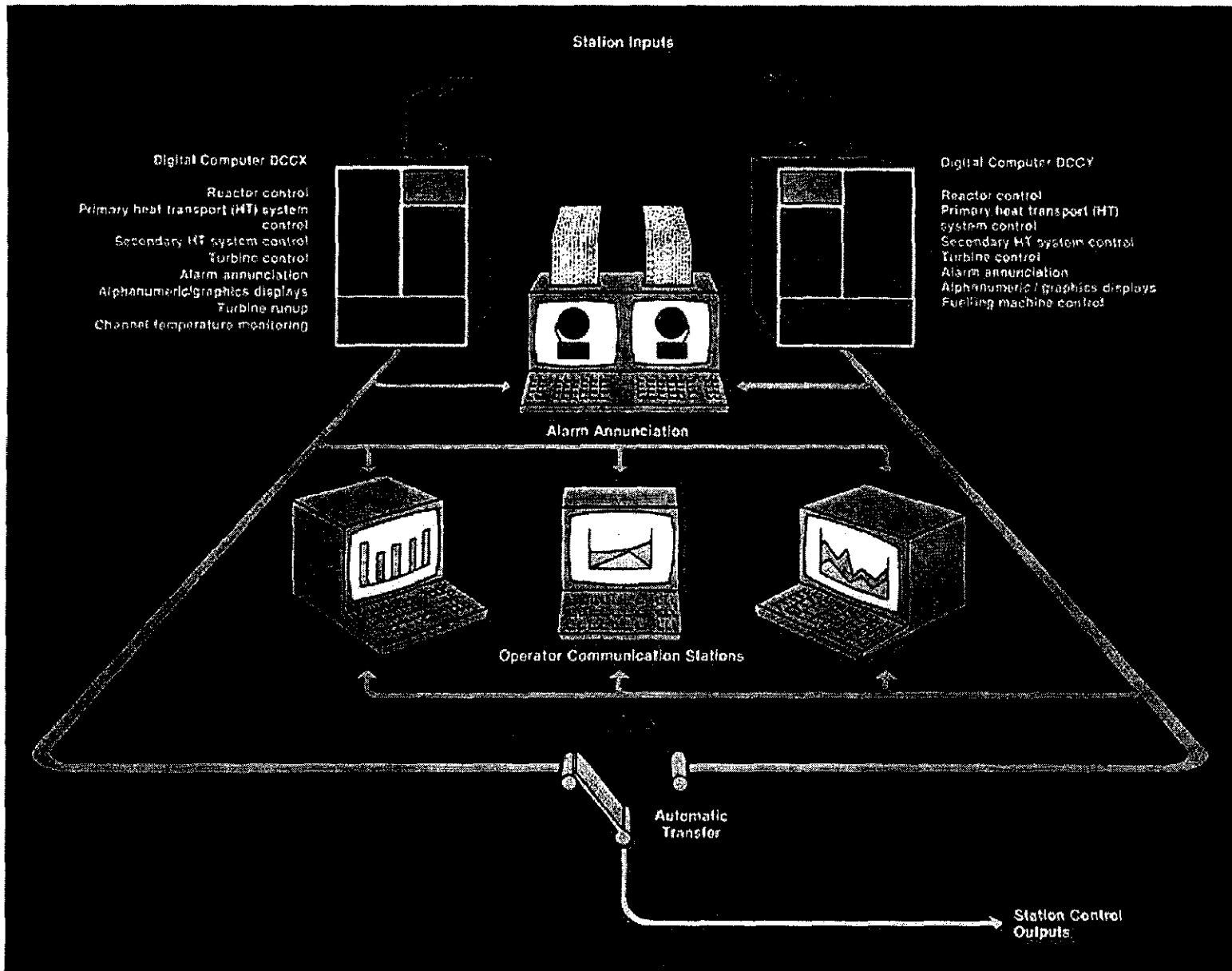


Figure 4: Instrumentation and Control

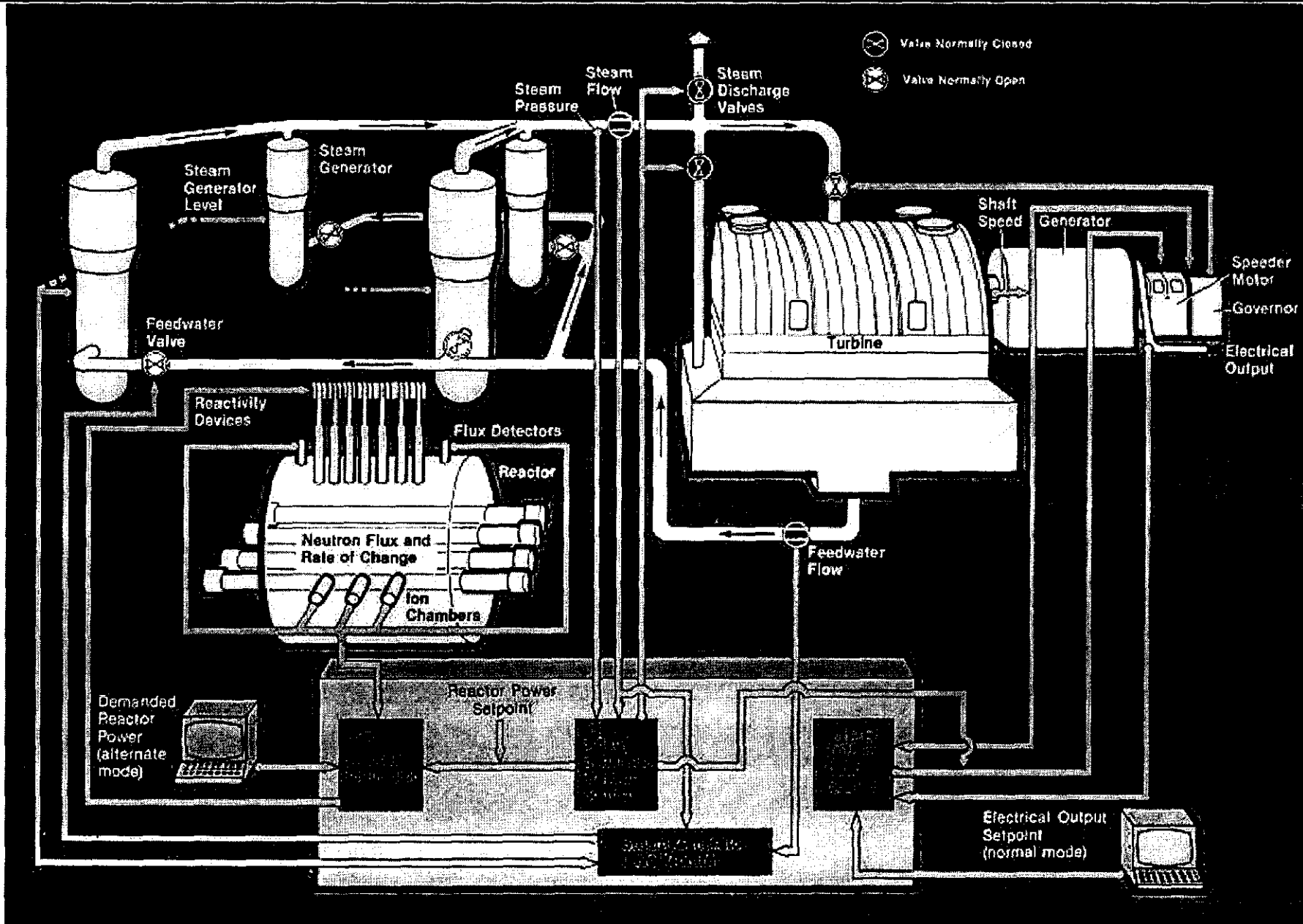


Figure 5: Overall Unit Control



## **6. REACTOR SHUTDOWN SYSTEMS (SDS#1 and SDS#2)**

- **there are two 'full capability' reactor shutdown systems, they are functionally and physically independent of each other, and each able to shut down the reactor;**
- **functional independence is provided by using different methods of shutdown: dropping solid neutron absorbing rods into the core for SDS#1, and injecting liquid poison into the moderator for SDS#2;**
- **physical independence is achieved by positioning the shutdown rods vertically through the top of the reactor, and the poison injection tubes horizontally through the sides of the reactor;**
- **the two shutdown systems respond automatically to both neutronic and process signals**
- **a very high level of independence is achieved by using diversity in:**
  - **the types of instruments used,**
  - **parameters measured**
  - **the control equipment hardware**
  - **software language**
  - **design and analysis teams.**

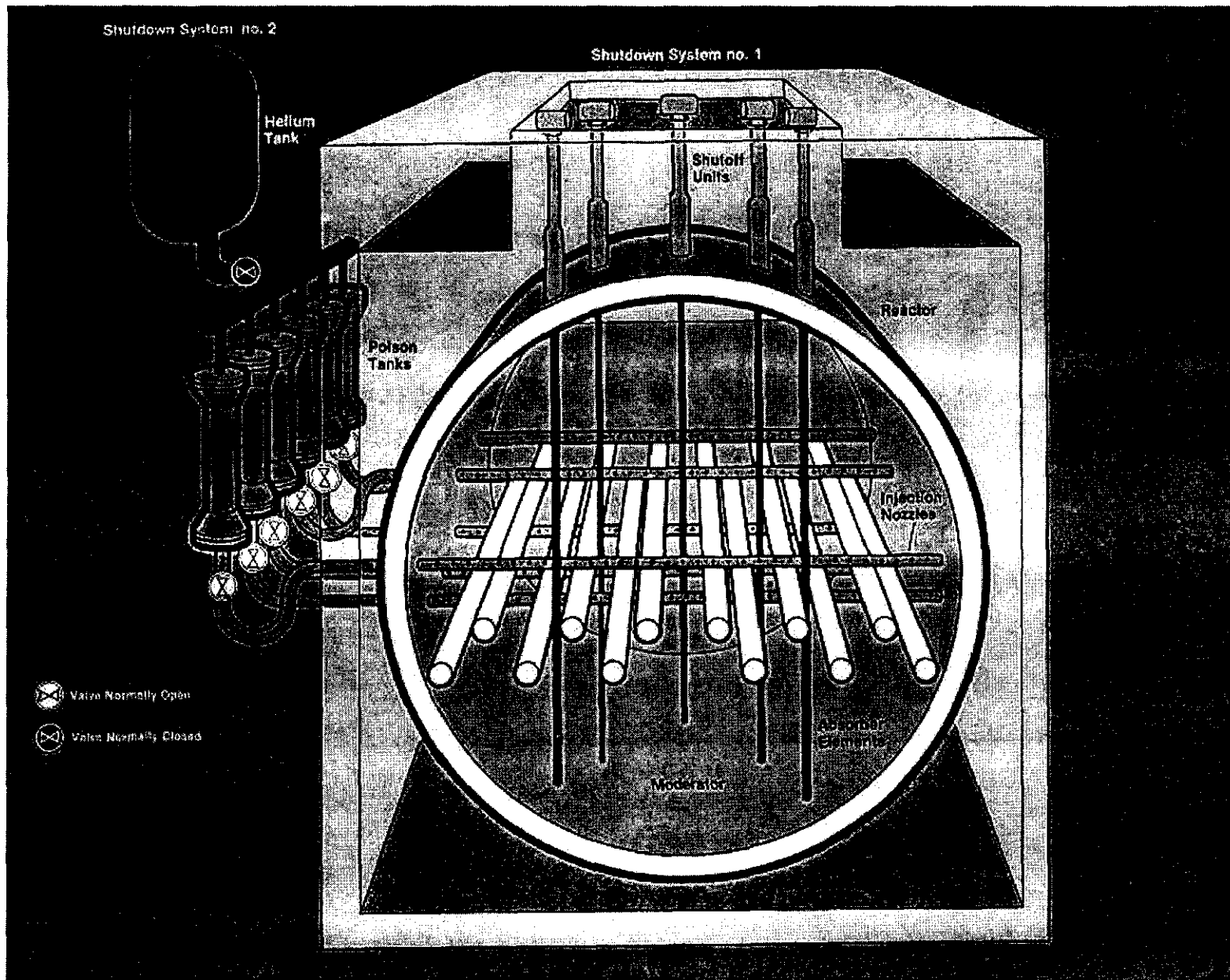
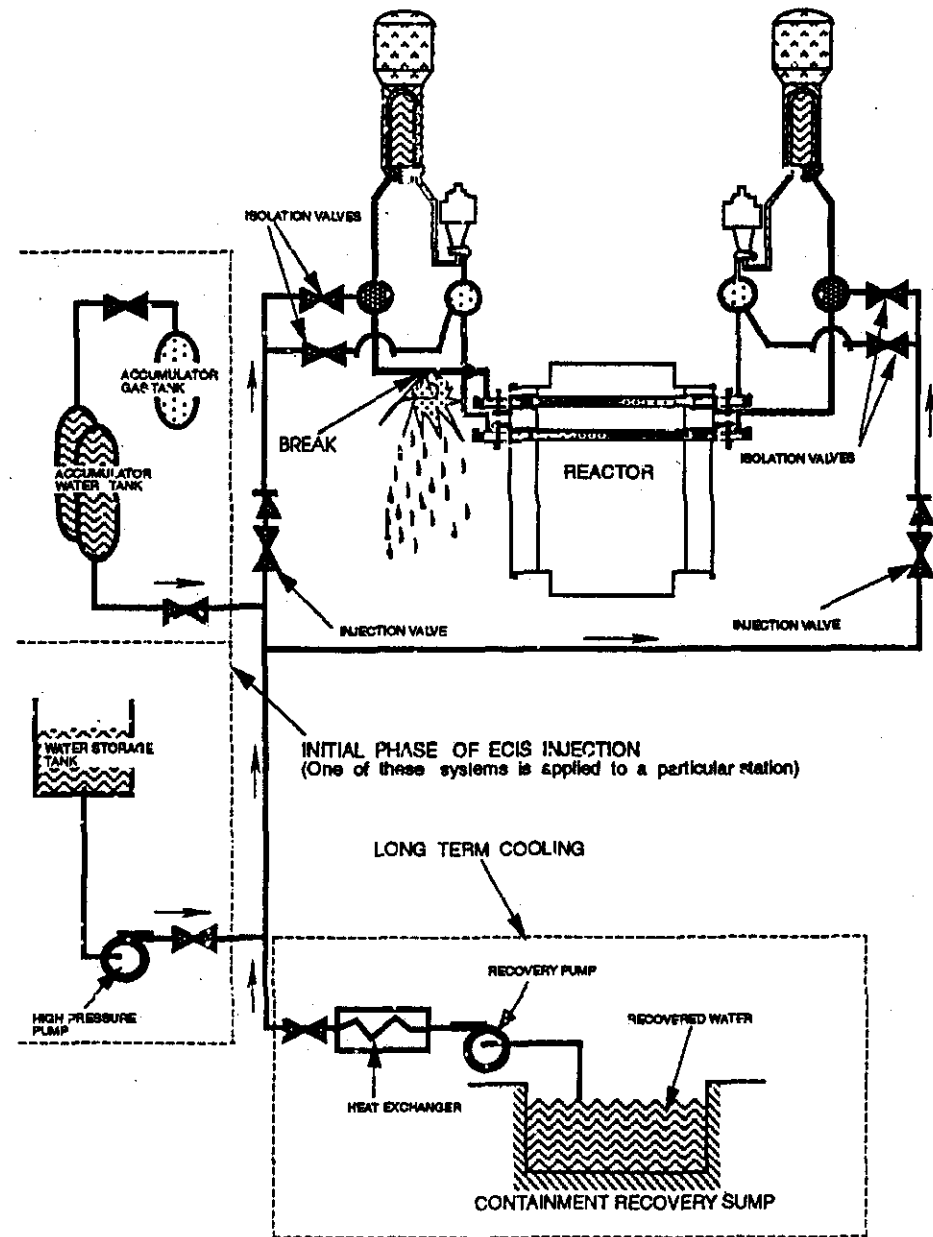


Figure 6: Reactor Shutdown Systems (SDS#1 and #2)

## 7. EMERGENCY CORE COOLING SYSTEM

- the system operates in the event of a loss of coolant accident (LOCA), and has three stages of operation: high, medium and low pressure;
- the initial injection of high pressure cooling water into the heat transport system is by opening the valve between the Gas Tank and the Water Injection Tanks (there is a corresponding opening of the boiler steam release valves to achieve rapid cooling of the boilers and further depressurization of the heat transport system);
- the source of medium pressure injection is the dousing tank, with either one of the two ECC pumps being able to supply 100% flow;
- low pressure operation uses the same ECC pumps, but with the water coming from the floor of the reactor building.



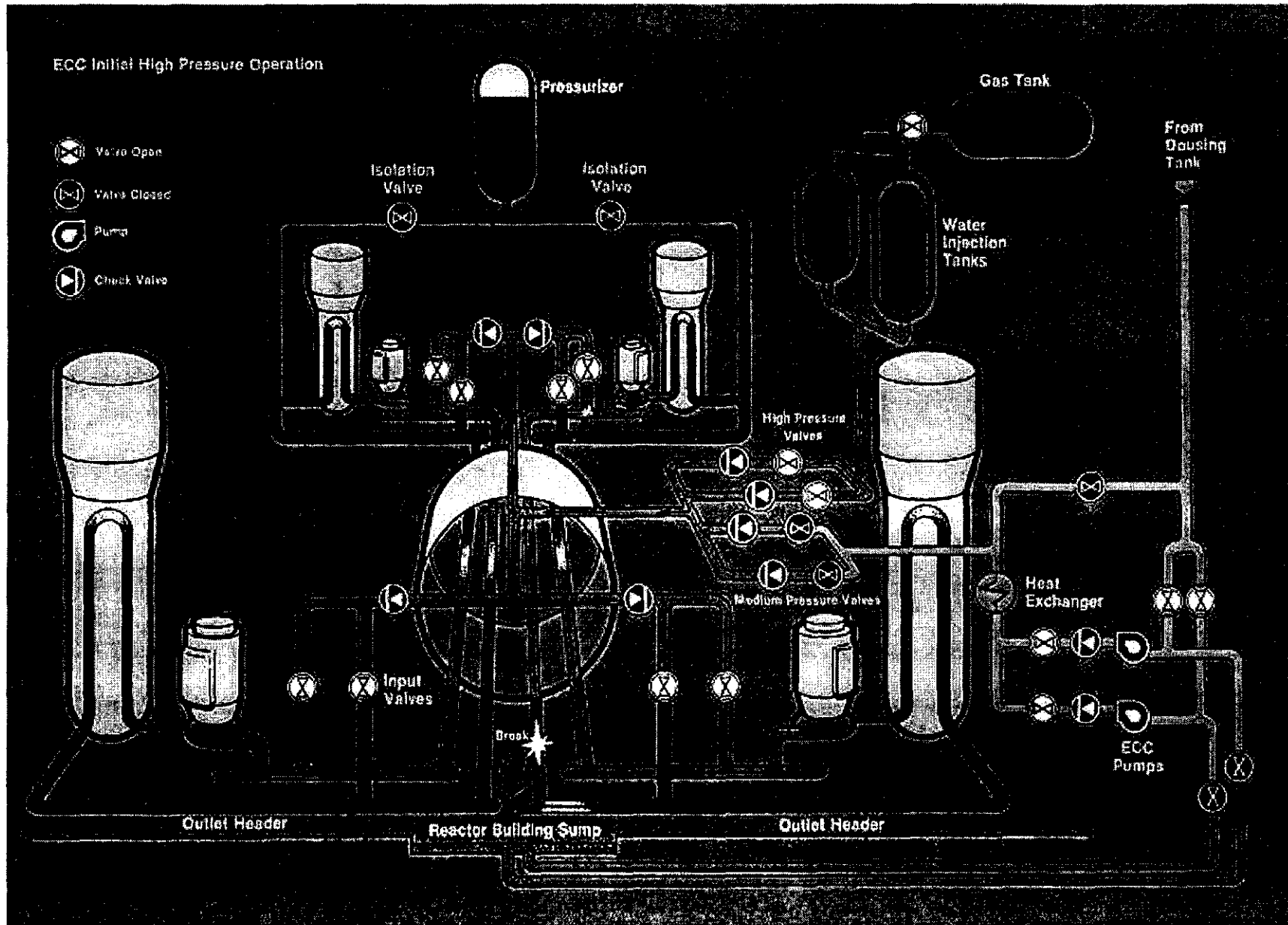


Figure 7: Emergency Core Cooling System

## 18. CONTAINMENT SYSTEM

- **the following systems provide a sealed envelope around the nuclear steam supply systems if an accidental release of radioactivity is detected:**
  - ⇒ **plastic lined pre-stressed post-tensioned pressure-retaining concrete containment structure;**
  - ⇒ **automatic dousing system;**
  - ⇒ **air coolers that provide a long-term containment atmosphere heat sink**
  - ⇒ **filtered air discharge system;**
  - ⇒ **access airlocks;**
  - ⇒ **automatic containment isolation system that closes all reactor building penetrations open to the containment atmosphere when an increase in containment pressure or radioactivity level is detected;**
- **these systems are designed to withstand the maximum pressure which could occur following the largest postulated loss-of-coolant accident;**

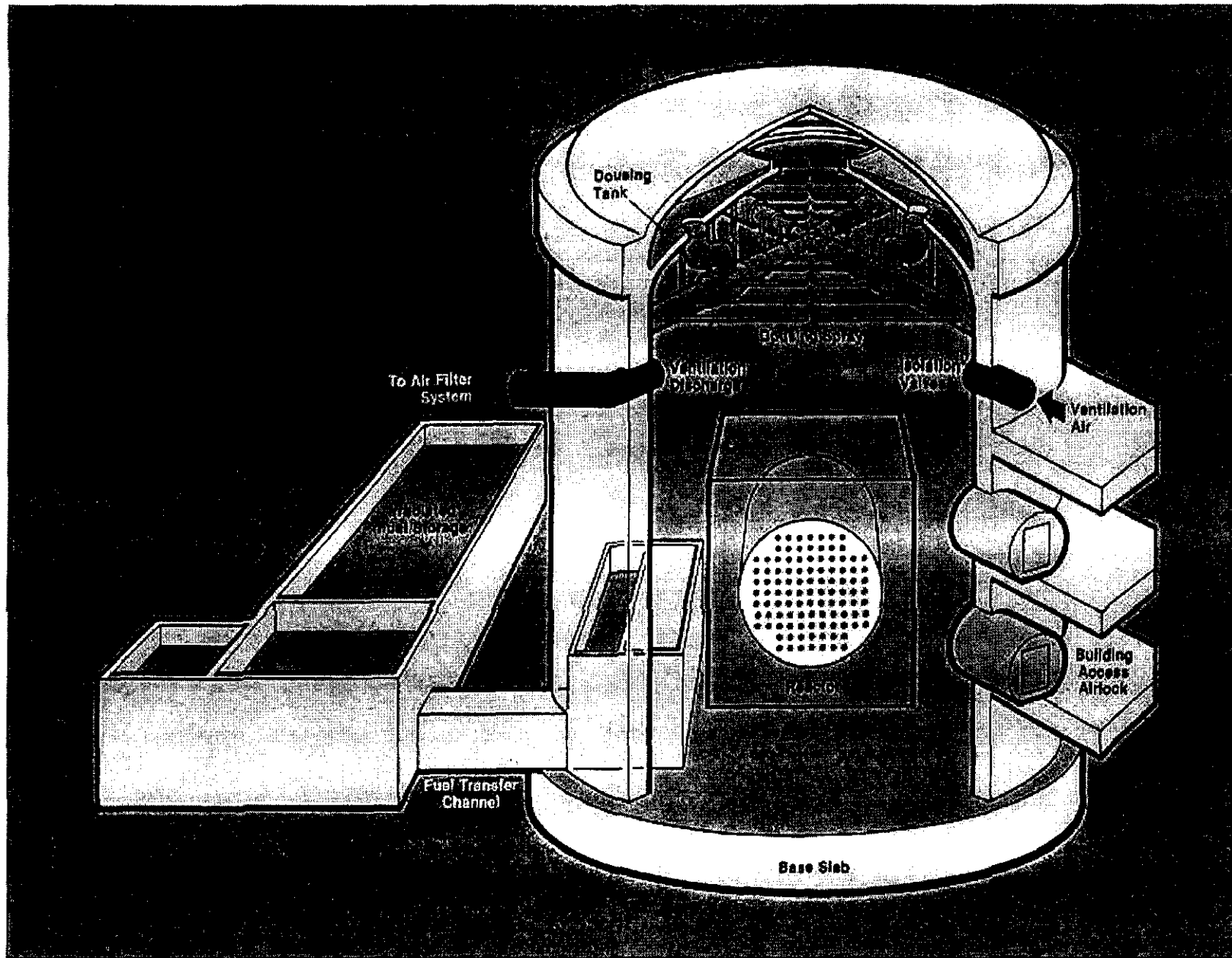
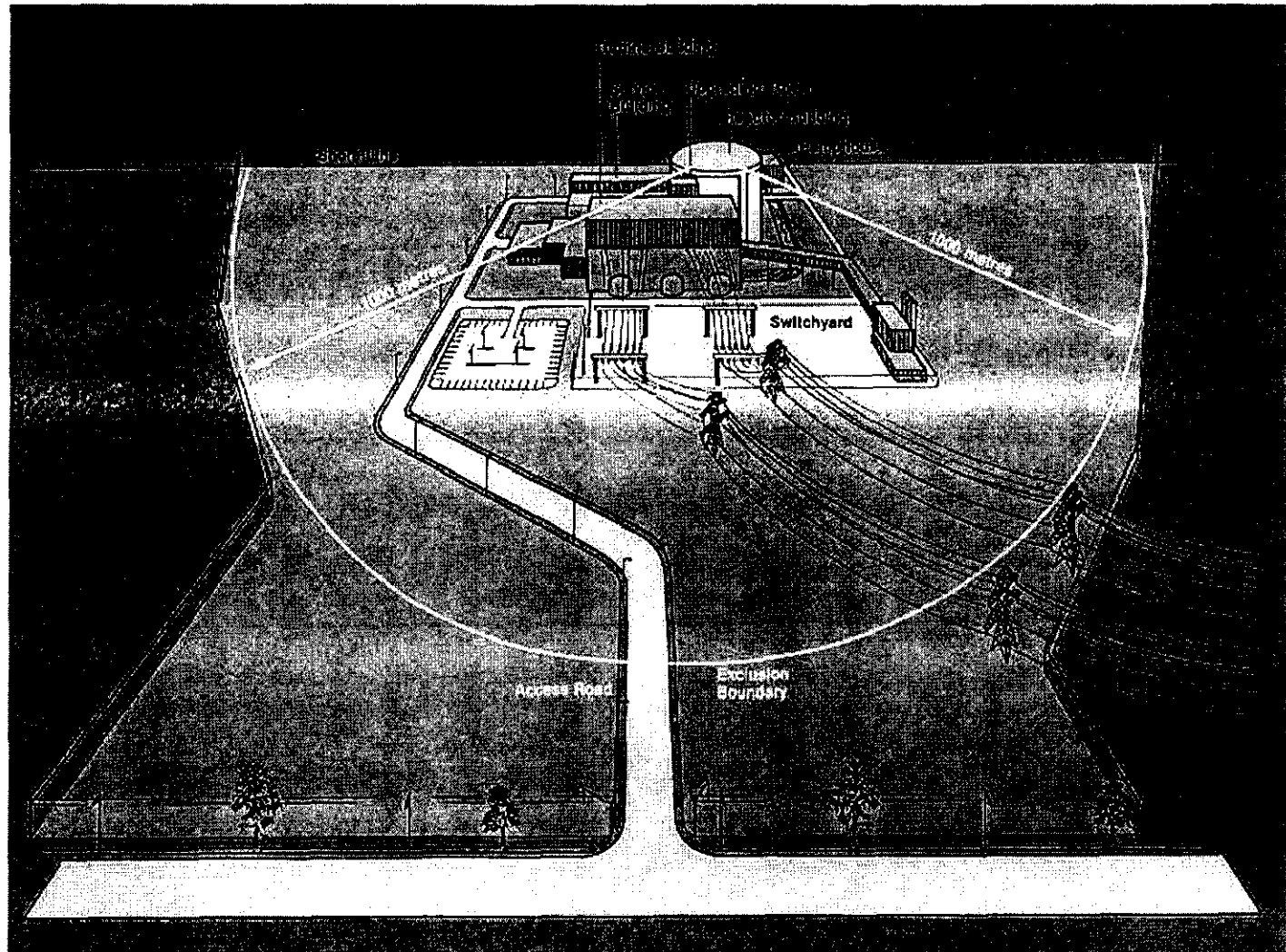


Figure 8: Containment System

## 9. SITE AND PLANT ARRANGEMENTS

- land area sufficient to provide the required exclusion zone (500 - 1000 meters)
- source of cooling water;
- connection to the electrical grid;
- geology suitable for foundations of the required structures;
- known level of seismic activity;
- transportation access.



## **CHAPTER 1: OVERALL UNIT**

### **MODULE E: SIMULATOR EXERCISES**

#### **MODULE OBJECTIVES:**

**At the end of this module, you will be able to:**

- 1. Star-up and initialize the Simulator;**
- 2. Find the parameters that are common to all the displays;**
- 3. Identify the parameters displayed on the Plant Overview and Turbine Generator pages;**
- 4. Maneuver unit power via the Unit Power Regulator page.**



## 1. SIMULATOR STARTUP

- double click on 'CANDU\_R4'
- on 'CANDU 9 Compact Simulator' screen click on 'OK' and 'STOP SERVER'
- when messages clear, double click anywhere on screen
- click 'OK' to 'Load Full Power IC?'
- the Simulator will display the 'Plant Overview' screen with all parameters initialized to 100% Full Power
- at the bottom right hand corner click on 'Run' to start the simulator

## 2. SIMULATOR INITIALIZATION

If at any time you need to return the Simulator to one of the stored Initialization Points, do the following:

- 'Freeze' the Simulator
- click on 'IC'
- click on 'Load IC'
- click on 'FP\_100.IC' for 100% full power initial state
- click 'OK' to 'Load C:\AECL\_P4\FP\_100.IC'
- click 'YES'
- click 'Return'
- Start the Simulator operating by selecting 'Run'.

### 3. LIST OF CANDU 9 COMPACT SIMULATOR DISPLAY SCREENS

1. Plant Overview
2. Shutdown Rods
3. Reactivity Control
4. Liquid Zones Control
5. Zonal Flux Trends
6. Flux Mapping
7. PHT Main Circuit
8. PHT Feed & Bleed
9. PHT Inventory Control
10. PHT Pressure Control
11. Bleed Condenser Control
12. Steam Generator Feed Pumps
13. Steam Generator Level Control Steam
14. Generator Level Trends
15. Steam Generator Level Manual Ctrl
16. Extraction Steam
17. Turbine Generator
18. RRS / DPR
19. UPR
20. Electrical GRP1 Class IV
21. Electrical GRP1 Class III
22. Electrical GRP1 Class I/II A
23. Electrical GRP1 Class I/II B
24. Electrical GRP1 Class I/II C
25. Elect GRP1 Class IV Loads 1
26. Elect GRP1 Class IV Loads 2
27. Elect GRP1 Class III Loads 1
28. Elect GRP1 Class III Loads 2
29. Trends

#### 4. COMPACT SIMULATOR DISPLAY COMMON FEATURES

Revision 4 of the CANDU 9 Compact Simulator is made up of 29 interactive display screens or pages. All of these screens have the same information at the top and bottom of the displays, as follows:

- top of the screen contains 21 plant alarms and annunciations; these indicate important status changes in plant parameters that require operator actions; each of these alarms will be discussed as part of the system that is generating it and/or is involved in the corrective action;
- top right hand corner shows the simulator status:
  - ⇒ the window under 'Labview' (this is the proprietary software that generates the screen displays) has a counter that is incrementing when Labview is running; if Labview is frozen (i.e. the displays cannot be changed) the counter will not be incrementing;
  - ⇒ the window displaying 'CASSIM' (this is the proprietary software that computes the simulation responses) will be green and the counter under it will not be incrementing when the simulator is frozen (i.e. the model programs are not executing), and will turn red and the counter will increment when the simulator is running;
- to stop (freeze) Labview click once on the 'STOP' sign at the top left hand corner; to restart 'Labview' click on the ⇒ symbol at the top left hand corner;
- to start the simulation click on 'Run' at the bottom right hand corner; to 'Stop' the simulation click on 'Freeze' at the bottom right hand corner;

## 5. COMPACT SIMULATOR DISPLAY COMMON FEATURES (continued)

- the bottom of the screen shows the values of the following major plant parameters:

- ⇒ Reactor Neutron Power (%)
- ⇒ Reactor Thermal Power (%)
- ⇒ Generator Output (%)
- ⇒ Main Steam Header Pressure (kPa)
- ⇒ Steam Generator Level (m)
- ⇒ OUC Mode ('Normal' or 'Alternate')

- the bottom left hand corner allows the initiation of two major plant events:

- ⇒ 'Reactor Trip'
- ⇒ 'Turbine Trip'

these correspond to hardwired push buttons in the actual control room;

- the box above the Trip buttons shows the display currently selected (i.e. 'Plant Overview'); by clicking and holding on the arrow in this box the titles of the other displays will be shown, and a new one can be selected by highlighting it;
- the remaining buttons in the bottom right hand corner allow control of the simulation one iteration at a time ('Iterate'); the selection of initialization points ('iC'); insertion of malfunctions ('Malf'); and calling up the 'Help' screen.

## 6. PLANT OVERVIEW PAGE

Shows a 'line diagram' of the main plant systems and parameters. No inputs are associated with this display. The systems and parameters displayed are as follows (starting at the bottom left hand corner):

- MODERATOR system is not simulated
- REACTOR is a 14 zone model, each zone being represented by a point kinetic model with six groups of delayed neutrons, and coupling coefficients that account for the interaction of the flux between adjacent zones; decay heat model uses a three group approximation; reactivity calculations include reactivity control and safety devices, Xenon, voiding in channels and power level changes. The parameters displayed are:
  - ⇒ Average Zone Level (% full)
  - ⇒ Neutron Power (% full power)
  - ⇒ Neutron Power Rate (%/ second)
- Heat Transport main loop, pressure and inventory control systems are shown as a single loop on the Plant Overview display, additional details will be shown on subsequent displays. The parameters displayed are:
  - ⇒ Reactor Outlet Header (ROH) and Reactor Inlet Header (RIH) average Temperature (°C) and Pressure (kPa)
  - ⇒ Pressurizer Level (m) and Pressure (kPa); D<sub>2</sub>O Storage Tank level (m)

## 6.1 PLANT OVERVIEW PAGE (continued)

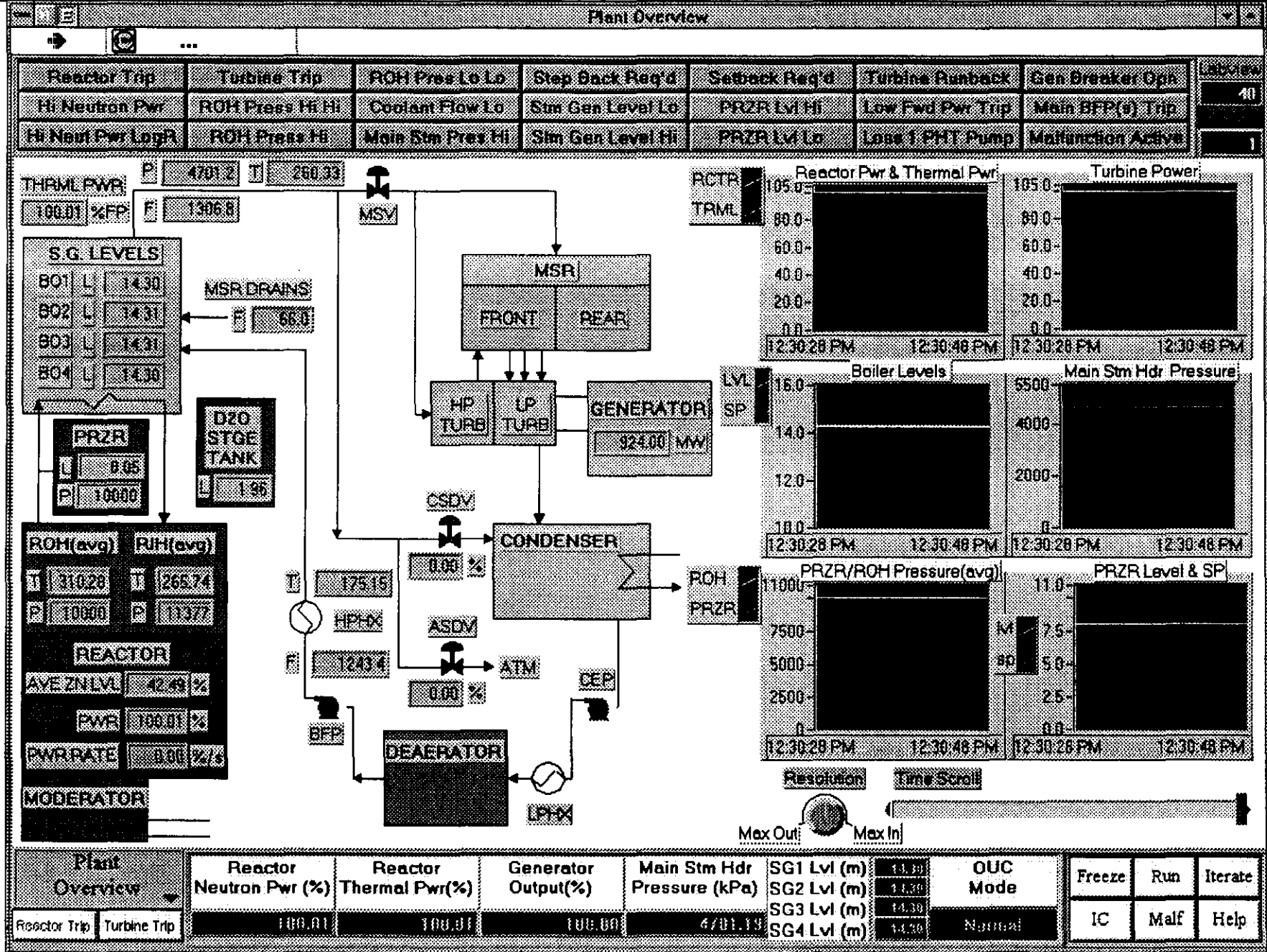
- The four Steam Generators are individually modeled, but only the level measurements are shown separately, for the flows, pressures and temperatures average values are shown. The parameters displayed are:
  - ⇒ Boiler 1, 2, 3, 4 Level (m)
  - ⇒ Steam Flow (kg/sec)
  - ⇒ Steam Pressure (kPa)
  - ⇒ Steam Temperature (°C)
  - ⇒ Moisture Separator and Reheater (MSR) Drains Flow (kg/sec)
  - ⇒ Status of control valves is indicated by their colour: green is closed, red is open; the following valves are shown for the Steam System:
    - Main Steam Stop Valves (MSV) status only
    - Condenser Steam Discharge Valves (CSDV) status and % open
    - Atmospheric Steam Discharge Valves (ASDV) status and % open
- Generator output (MW) is calculated from the steam flow to the turbine
- Condenser and Condensate Extraction Pump (CEP) are not simulated
- Simulation of the feedwater system is very much simplified; the parameters displayed on the Plant Overview screen are:
  - ⇒ Total Feedwater flow to the steam generators (kg/sec)
  - ⇒ Average Feedwater temperature after High Pressure Heater (HPHX)
  - ⇒ Status of Boiler Feed Pumps (BFP) is indicated as red if any pumps are 'ON' or green if all the pumps are 'OFF'

## 6.2 PLANT OVERVIEW PAGE (continued)

Six trend displays show the following parameters:

- Reactor Neutron Power and Reactor Thermal Power (0-100%)
- Turbine Power (0-100%)
- Boiler Levels - actual and setpoint (m)
- Main Steam Header Pressure (kPa)
- Pressurizer and Reactor Outlet Header (average) Pressure (kPa)
- Pressurizer Level - actual and setpoint (m)

Note that while the simulator is in the 'Run' mode, all parameters are being continually computed and all the displays are available for viewing and inputting changes.





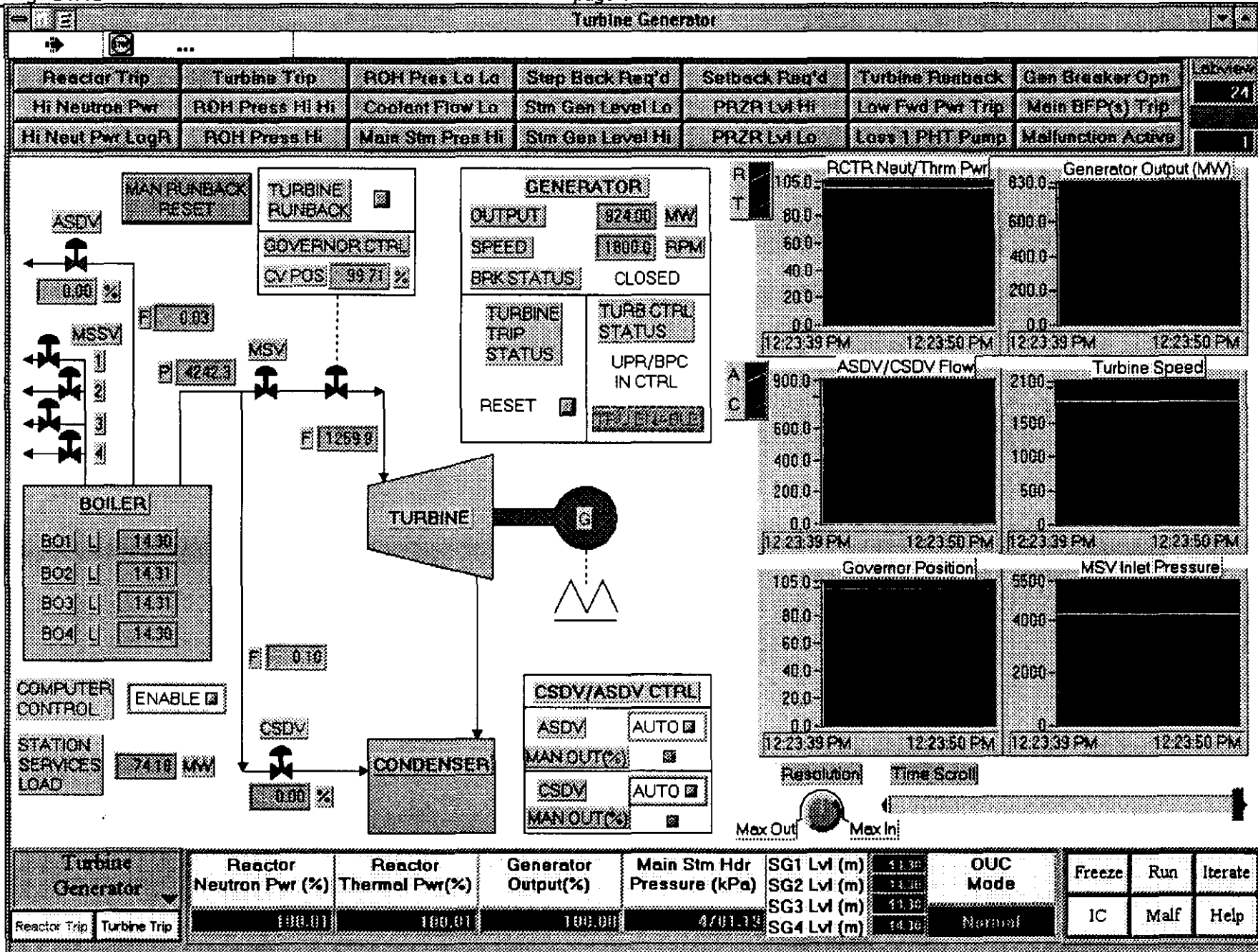
## 7. TURBINE GENERATOR PAGE

Shows the main parameters and controls associated with the Turbine and the generator. The parameters displayed are:

- Boiler 1, 2, 3, 4 Level (m)
- status of Main Steam Safety Valves (MSSV)
- status, opening and flow through the Atmospheric Steam Discharge Valves (ASDV) and the Condenser Steam Discharge Valves (CSDV)
- Steam Flow to the Turbine (kg/sec)
- Governor Control Valve Position (% open)
- Generator Output (MW)
- Turbine/Generator Speed of Rotation (rpm)
- Generator Breaker Trip Status
- Turbine Trip Status
- Turbine Control Status
- All the trend displays have been covered elsewhere or are self explanatory

The following pop-up menus are provided:

- TURBINE RUNBACK - sets Target (%) and Rate (%/sec) of runback when 'Accept' is selected
- TURBINE TRIP STATUS - Trip or Reset
- ASDV and CSDV AUTO/MANUAL Control - AUTO Select, following which the Manual Position of the valve may be set



## 8. UPR PAGE

This screen permits control of station load setpoint and its rate of change while under Unit Power Regulator (UPR) control, i.e. 'normal' mode. Control of the Main Steam Header Pressure is also through this screen, but this is not usually changed under normal operating conditions.

- OUC (overall Unit Control) MODE can be changed from NORMAL to ALTERNATE.
- TARGET LOAD - on selection Station Load (%) and Rate of Change (%/sec) can be specified; change becomes effective when 'Accept' is selected.
  - ⇒ The OPERATOR INP TARGET is the desired setpoint inserted by the operator; the CURRENT TARGET will be changed at a POWER RATE specified by the operator.
  - ⇒ Note that the RANGE is only an advisory comment, numbers outside the indicated range of values may be input on the Simulator.
- MAIN STEAM HEADER PRESSURE SETPOINT (MPa) - alters the setpoint, which is rarely done during power operation. Caution must be exercised when using this feature on the Simulator, since the requested change takes place in a step fashion as soon as the change is made; changes should be made in increments of 0.1 MPa.

UPR

Reactor Trip	Turbine Trip	RDH Pres Lo Lo	Step Back Req'd	Seiback Req'd	Turbine Ruckback	Gen Breaker Opr
Hi Neutron Pwr	RDH Pres Hi Hi	Coolant Flow Lo	Stm Gen Level Lo	PRZR Lvl Hi	Low Fwd Pwr Trip	Main BFP(s) Trip
Hi Neut Pwr LogR	RDH Pres Hi	Main Stm Pres Hi	Stm Gen Level Hi	PRZR Lvl Lo	Loss 1 PHT Pump	Malfunction Active

QUC MODE: NORMAL

RCTR: TRML

UNIT POWER RATE & TARGET LOAD

CONTROLLED VARIABLE	CURRENT TARGET	OPERATOR INP TARGET	RANGE
TARGET LOAD(%) <input type="checkbox"/>	100.00	100.00	5 TO 100
POWER RATE (%/S)	0.60	0.60	0.01 TO 1

Reactor Pwr & Thermal Pwr

Main Steam Hdr Pressure & SP

MAIN STEAM HEADER PRESSURE SETPOINT

CONTROLLED VARIABLE	CURRENT TARGET	OPERATOR INP TARGET	RANGE
MAIN STM HDR PRES SETPOINT(MPa) <input type="checkbox"/>	4.701	4.701	4 TO 5

Current Target Load & Turbine Pwr

Boiler Level

Resolution: ● Time Scroll:

Max Out ● Max In

UPR System	Reactor Neutron Pwr (%)	Reactor Thermal Pwr(%)	Generator Output(%)	Main Stm Hdr Pressure (kPa)	SG1 Lvl (m)	SG2 Lvl (m)	SG3 Lvl (m)	SG4 Lvl (m)	OUC Mode	Freeze	Run	Iterate
Reactor Trip	100.01	100.01	100.00	4.701	11.50	11.50	11.50	11.50	Normal	IC	Malf	Help

## 9. SIMULATOR EXERCISES

### 9.1 POWER MANEUVER: 10% Power Reduction and Return to Full Power

- Initialize Simulator to 100% full power
- verify that all parameters are consistent with full power operation.
- select the UPR page, and change the scale on the “Reactor Pwr & Thermal Pwr” and “Current Target Load & Turbine Pwr” graphs to be between 80 and 110 percent, the “Main Steam Hdr Pressure & SP” to 4500 and 5000 kPa, “Boller Level” to 13 and 15 meters, and set “Resolution” to “Max Out”.
- reduce unit power in the ‘normal’ mode, i.e.
  - ⇒ using the UPR display
  - ⇒ select ‘TARGET LOAD (%)’ pop-up menu
  - ⇒ In pop-up menu lower ‘target’ to 90.00% at a ‘Rate’ of 1.0 %/sec
  - ⇒ ‘Accept’ and ‘Return’
- observe the response of the displayed parameters until the transients in Reactor Power and Steam Pressure are completed (approximately 4 minutes and full time scale on the graph) without freezing the Simulator and/or stopping Labview, and explain the main changes
- continuing the above operation, raise “UNIT POWER” to 100% at a rate of 1.0%FP/sec.

## 9.2 RESPONSE TO POWER MANEUVER

- initialize the Simulator to 100%FP, reduce power using UPR in 25% steps at 0.5%/sec (trip the reactor for the 0% state) and record the following values:

Parameter	Unit	100%	75%	50%	25%	0%	Comments
Reactor Power	%						
ROH Pressure	MPa						
ROH Temperature	°C						
RIH Pressure	MPa						
RIH Temperature	°C						
Pressurizer Level	m						
HT Pump Flow	Mg/s						
Boiler Pressure	MPa						
Boiler Temperature	°C						
Boiler Level	m						
Steam Flow	kg/s						
Feedwater Flow	kg/s						
Turbine-Generator Power	%						

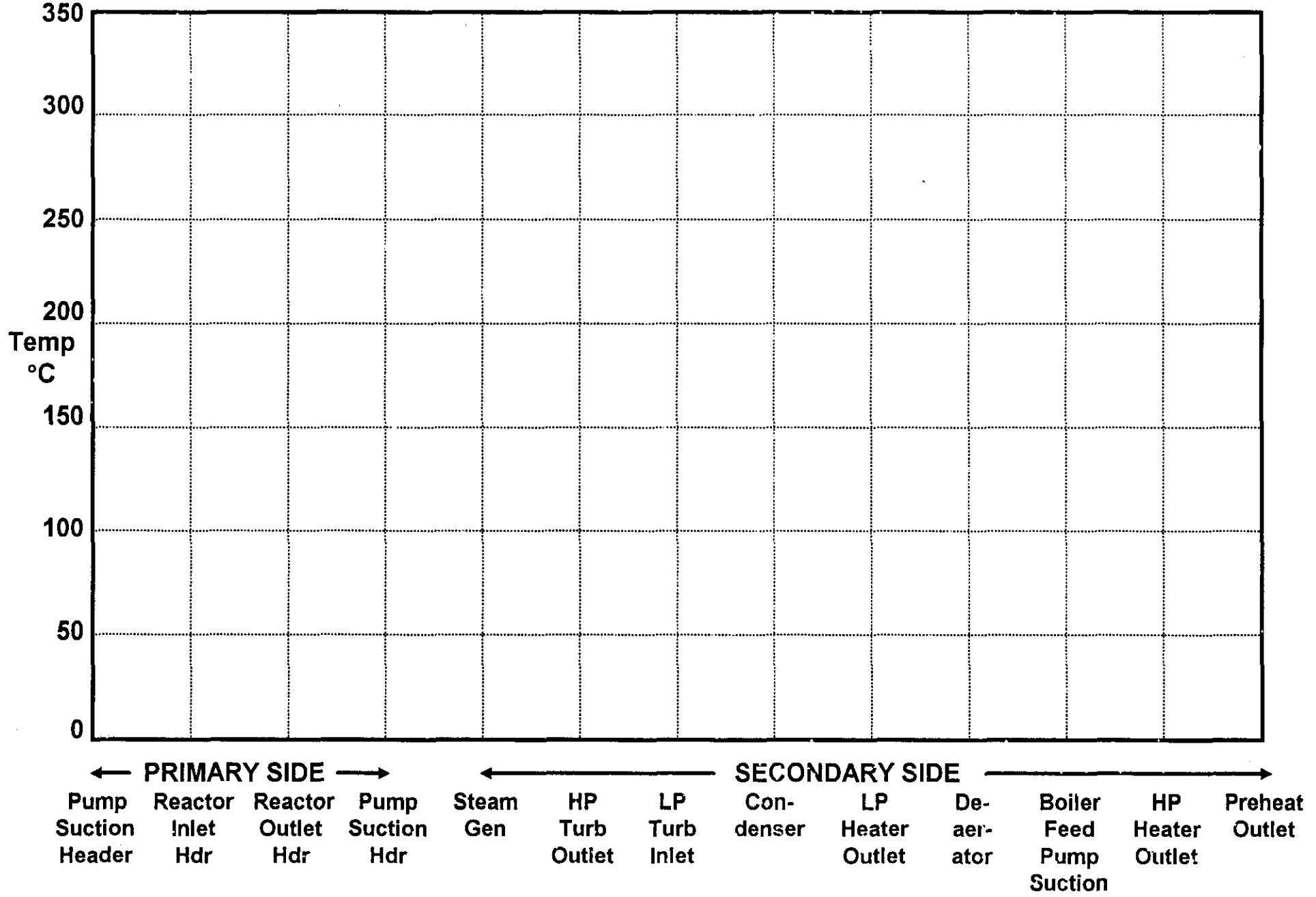
Under "Comments" please note type of parameter change as a function of reactor power 0% → 100%FP: constant, linear increase or decrease, non-linear increase or decrease

### 9.3 TEMPERATURE PROFILE ACROSS A CANDU 9 UNIT AT FULL POWER

- Initialize the Simulator to 100% Full Power.
- Record the values of the parameters in the table below.

Station Equipment	Pressure (kPa)	Temperature (°C)
Reactor Inlet Header		
Reactor Outlet Header		
Steam Generator		
HP Turbine Exhaust	900	170
LP Turbine Inlet	900	230
Condenser	5	35
LP Heater Outlet	700	100
Deaerator		130
Boiler Feedpump Inlet		
HP Heater Outlet		
Preheater Outlet		

- Plot these parameters on the attached grid.





## **CHAPTER 1: OVERALL UNIT**

### **MODULE D: CANDU BALANCE OF PLANT, I&C AND SAFETY SYSTEMS**

#### **MODULE OBJECTIVES:**

At the end of this module, you will be able to describe the following for the Balance of Plant Systems of a CANDU generating station:

1. The main functions and components of each major process and process support system;
2. The main functions and components of each major control system;
3. The key process, control and safety related interactions between the major systems

## 1. TURBINE, GENERATOR, CONDENSATE AND FEEDHEATING SYSTEMS

all existing CANDU generating stations have turbine assemblies that consists of tandem compound units, with one double flow high pressure cylinder, and three double flow low pressure cylinders with external moisture separators and live steam reheaters between the high and low pressure stages

- the Governing system controls the turbine's speed of rotation when the generator is not synchronized to the grid, otherwise the governing system determines turbine/generator power;

### 1.1 GENERATOR

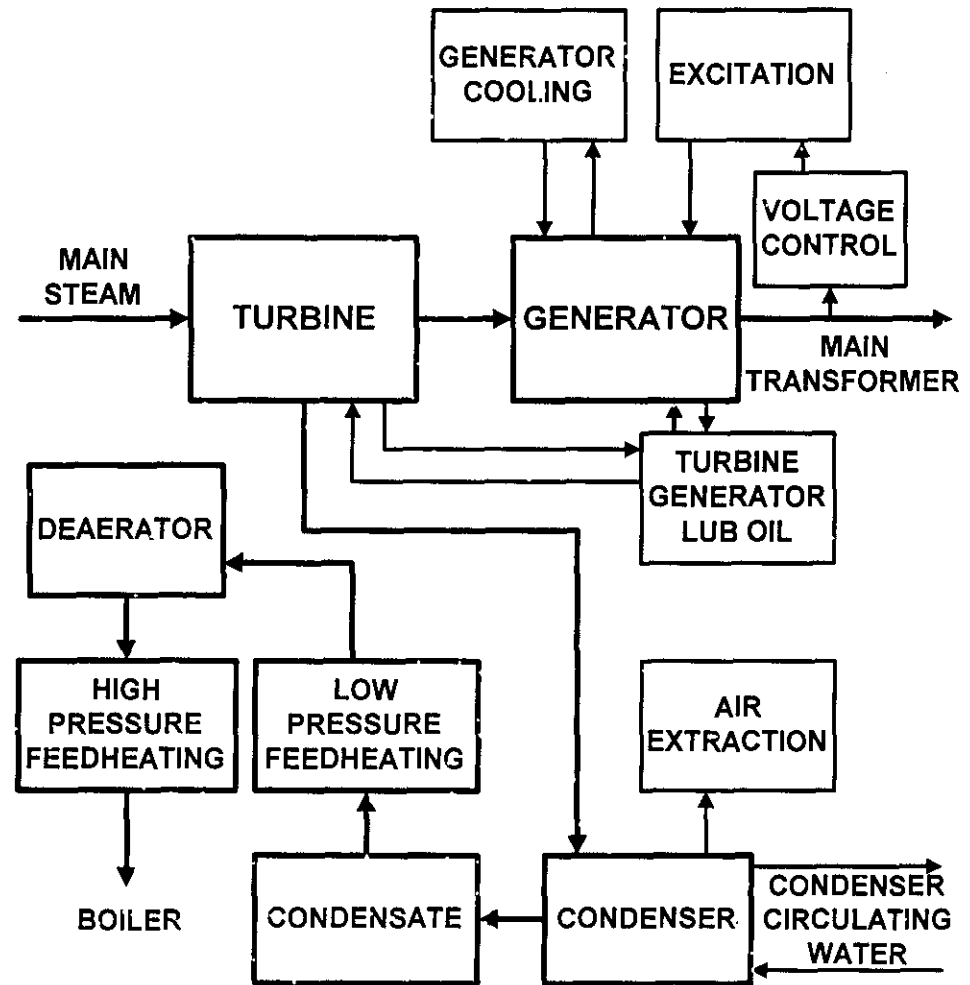
- three phase four pole machine directly coupled to the turbine;
- output voltage (usually) 24,000 volts;
- cooling of the rotor winding and stator core is by hydrogen, and of the stator winding by water.

### 1.2 CONDENSER

- consists of three separate shells, one for each low pressure turbine cylinder;
- can handle full steam by-pass flow when the turbine is not available.

### 1.3 FEEDHEATING

- uses extraction steam to preheat the feedwater in order to optimize thermodynamic efficiency;
- consists of three low pressure (LP), a deaerator, and two HP heaters;
- feed pumps return the feedwater to the boilers.



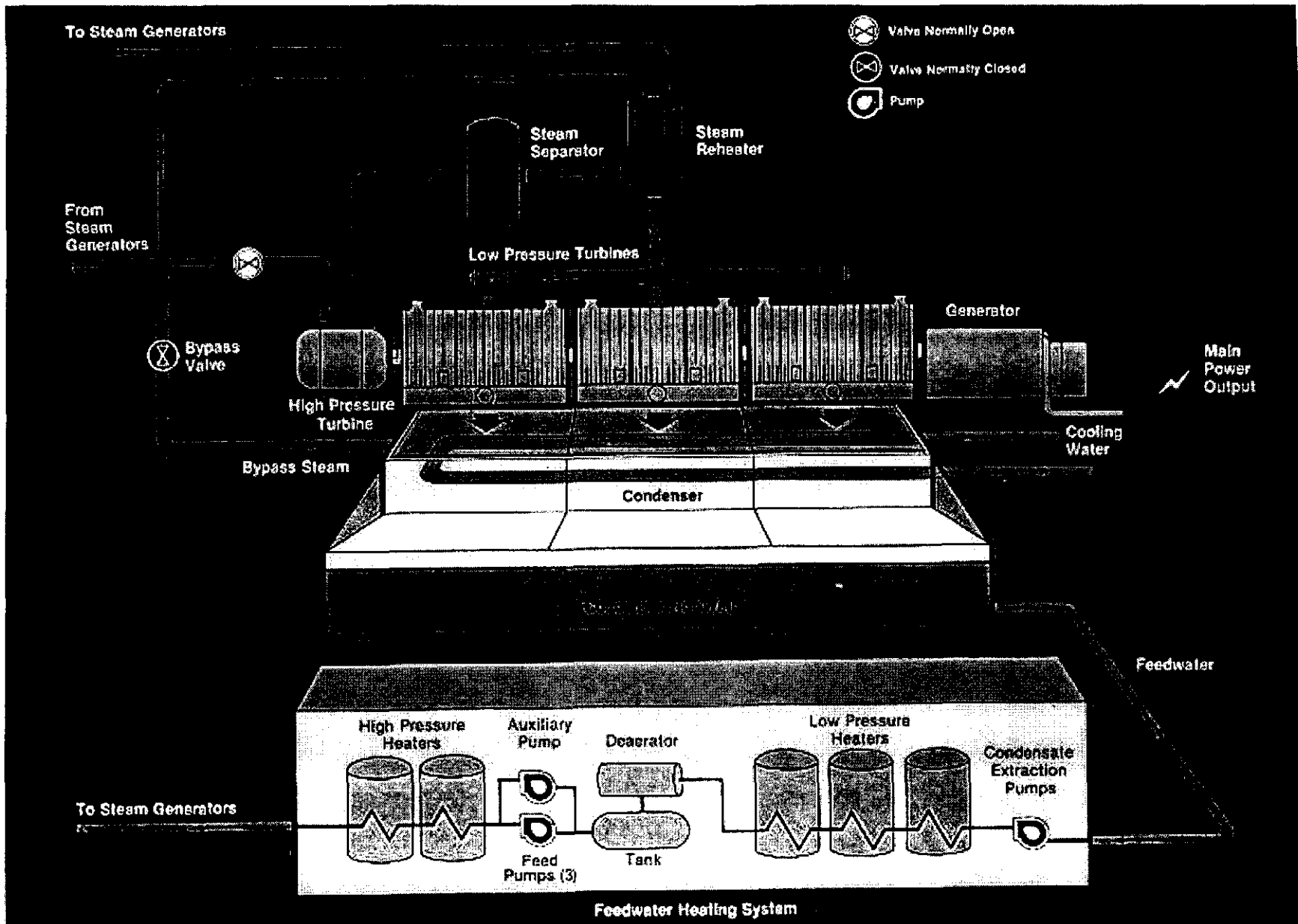
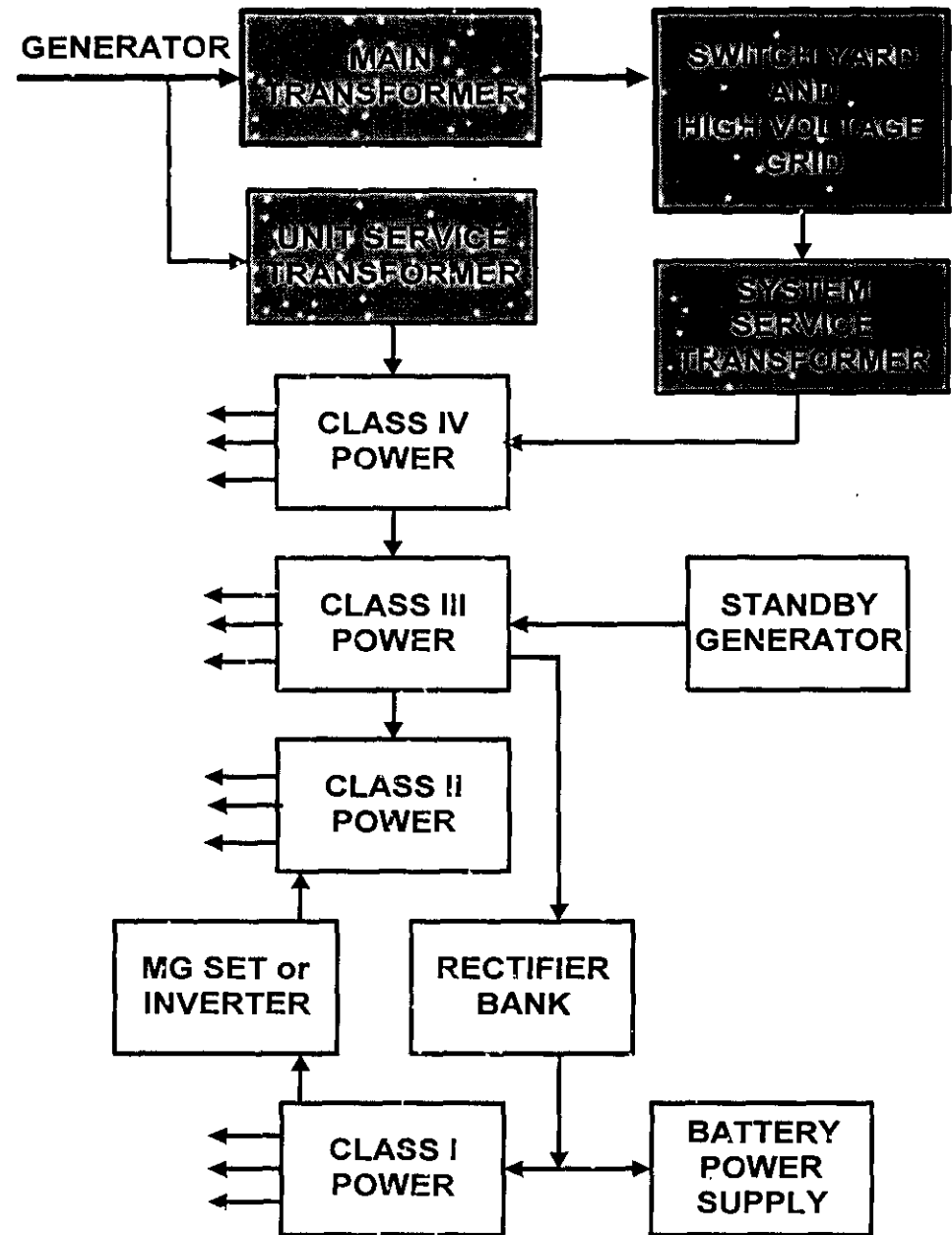
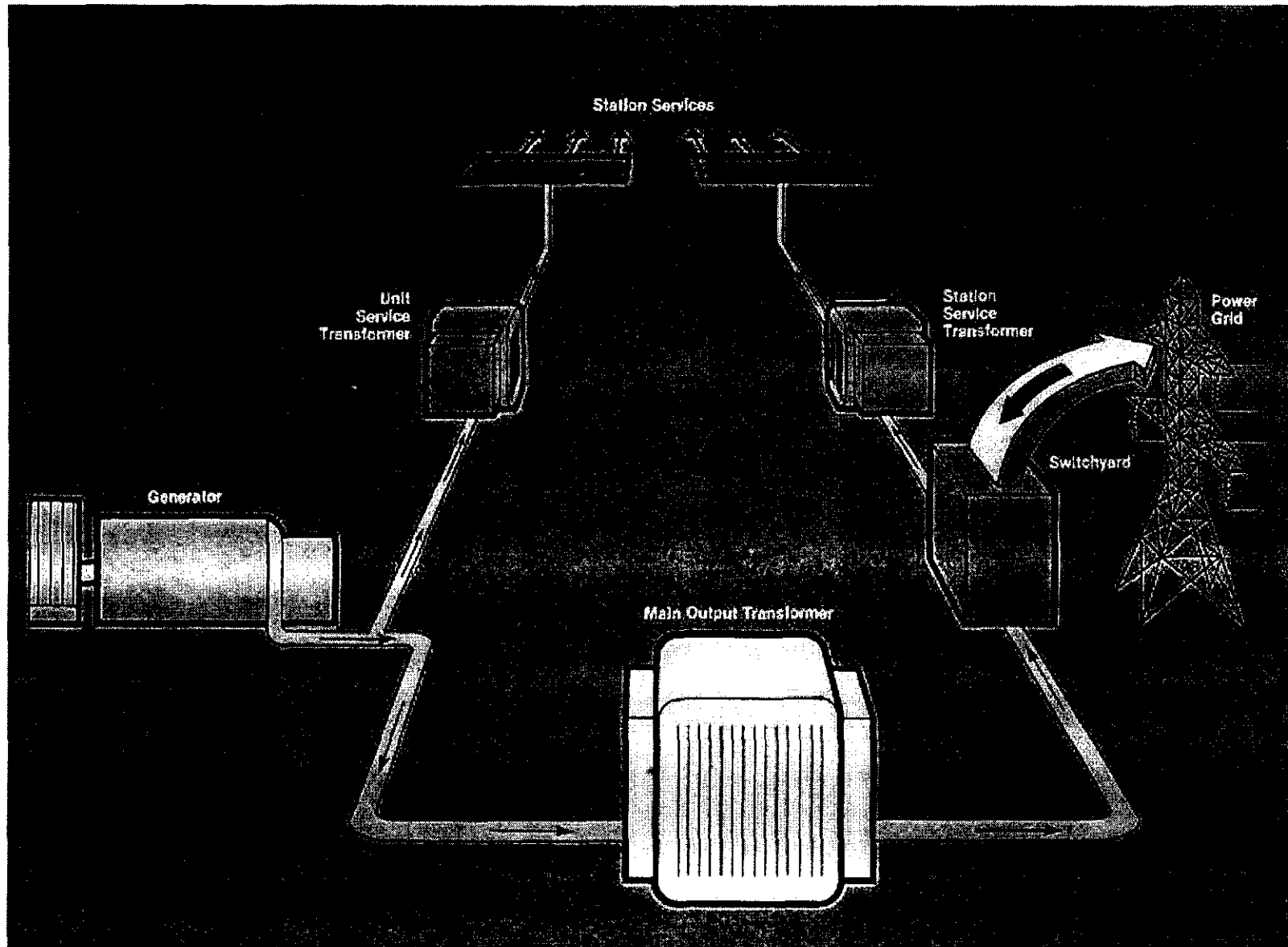


Figure 1: TURBINE, GENERATOR, CONDENSATE AND FEEDHEATING SYSTEMS

## 2. ELECTRIC POWER SYSTEM

- the output of the generator is stepped up in voltage by the Main Output and Unit Service transformers;
- the switchyard contains the breakers and disconnect switches which interconnect the station and the grid, and have automatic control to ensure the safe flow of electric power;
- unit service power is normally provided by the two 100 percent capacity transformers, the Unit Service transformer and the System Service transformer; an automatic transfer system ensures continuity of supply as long as one of the high voltage supplies are available;
- the unit service power is distributed and further stepped down in voltage as required.





**Figure 2: Electric Power Output System**

### 3. UNIT ELECTRIC POWER SERVICES

The power supplies are classified in terms of their level of reliability.

#### 3.1 Class IV Power

- supplies all major loads directly and all station equipment under normal operating conditions via the other classes;
- may be unavailable for extended periods (hrs);
- highest distribution voltage within the station (4 kV to 14 kV AC).

#### 3.2 Class III Power

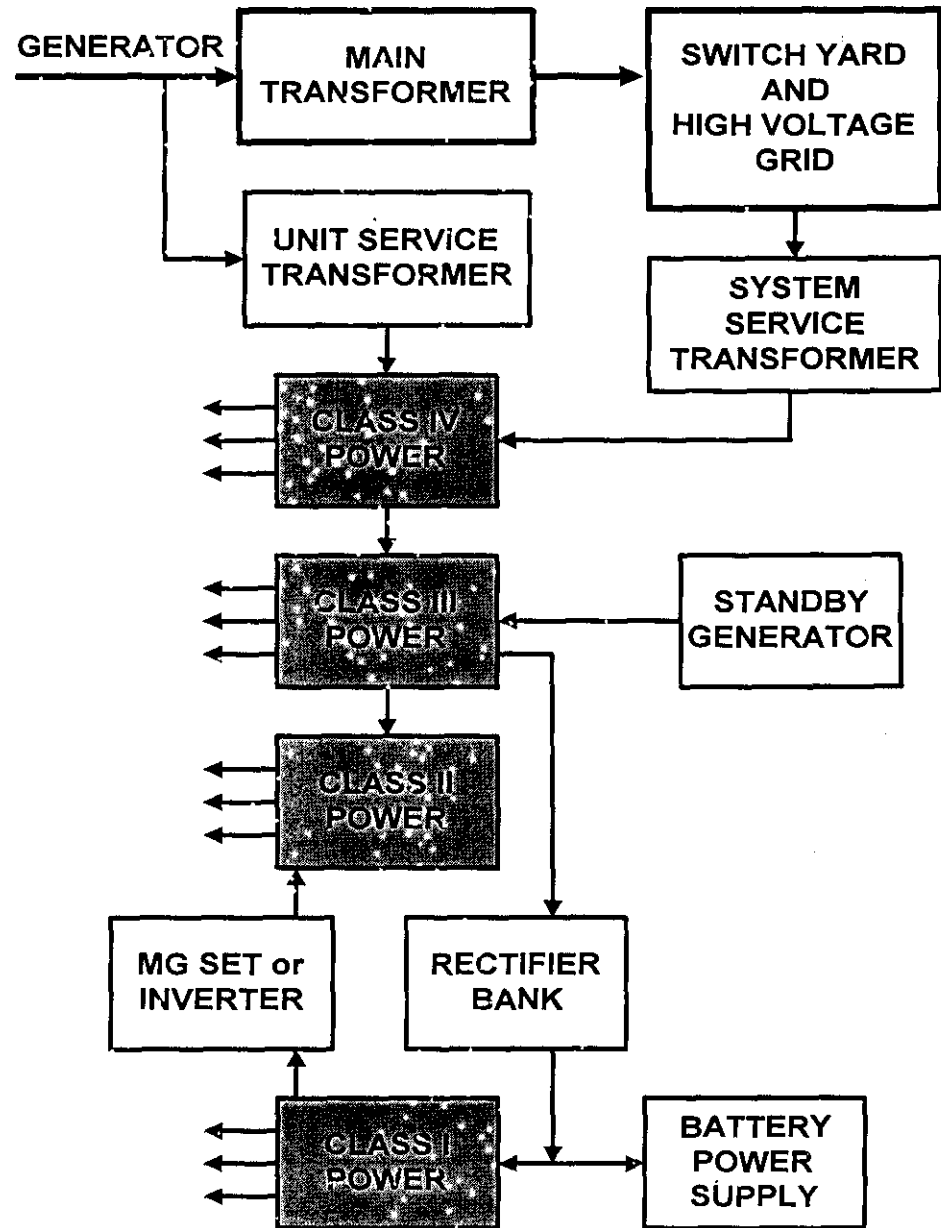
- supplies all loads necessary for safe shutdown of reactor and turbine;
- supplied by on-site Standby Generators if cannot be supplied from Class IV;
- may be unavailable for 3 minutes;
- typically 400 V to 5 kV AC.

#### 3.3 Class II Power

- supplies equipment and instrumentation essential to safe station operation;
- uninterruptible, supplied from batteries via Class I when cannot be supplied from Class III;
- typically 50 V to 250 V AC.

#### 3.4 Class I Power

- uninterruptible supply for all essential equipment;
- typically 50V to 250 V DC.



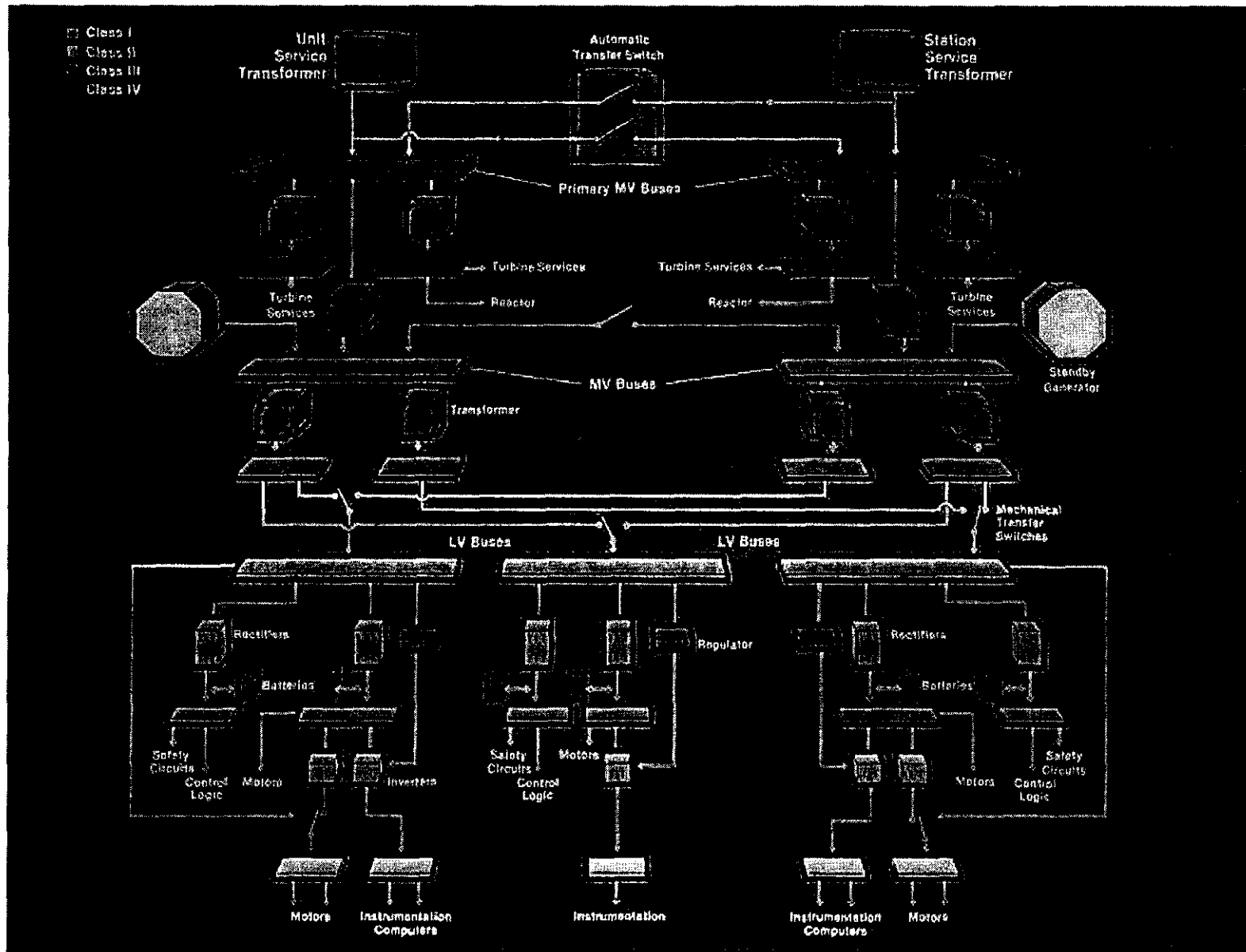


Figure 3: Unit Electric Power Distribution Systems

#### **4. INSTRUMENTATION AND CONTROL**

- **digital computers are used for station control, alarm annunciation, graphical data display and logging;**
- **there are two independent computers, both normally running, but each capable of controlling the unit;**
- **only the 'controlling' computer's outputs are connected to the field devices;**
- **a fault in any essential part of one computer results in automatic transfer of control to the other computer;**
- **if both computers fail the unit is automatically shut down;**
- **alarm messages are presented on two colour monitors, and line printers provide a chronological record of all alarm conditions;**
- **operator communication stations consist of a colour monitor and keyboard, and are the prime means by which the operator monitors and controls the unit;**
- **all major process systems are controlled by the dual redundant computer system;**
- **the safety systems use triplicated instrumentation, and are independent of the control computers.**



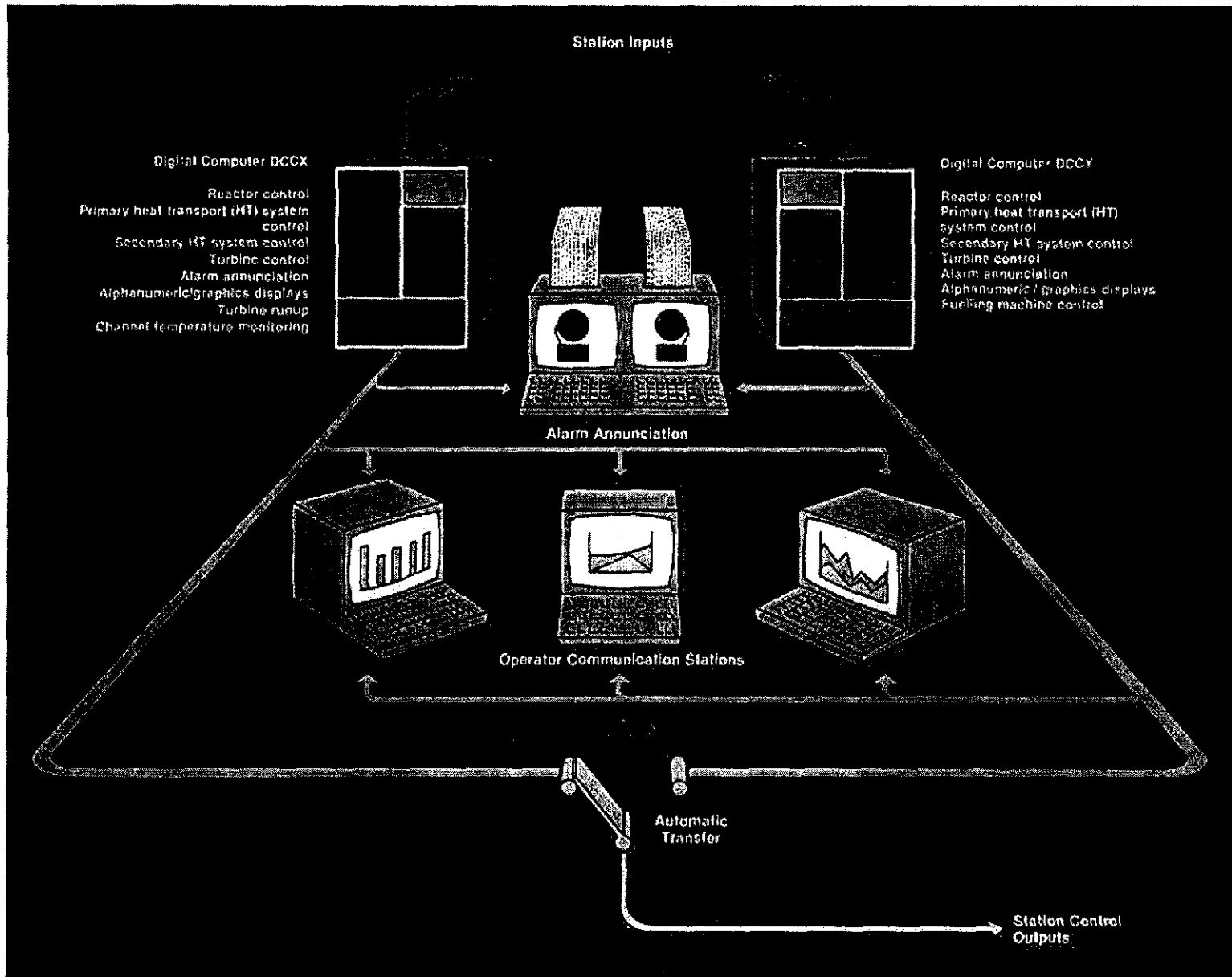


Figure 4: Instrumentation and Control

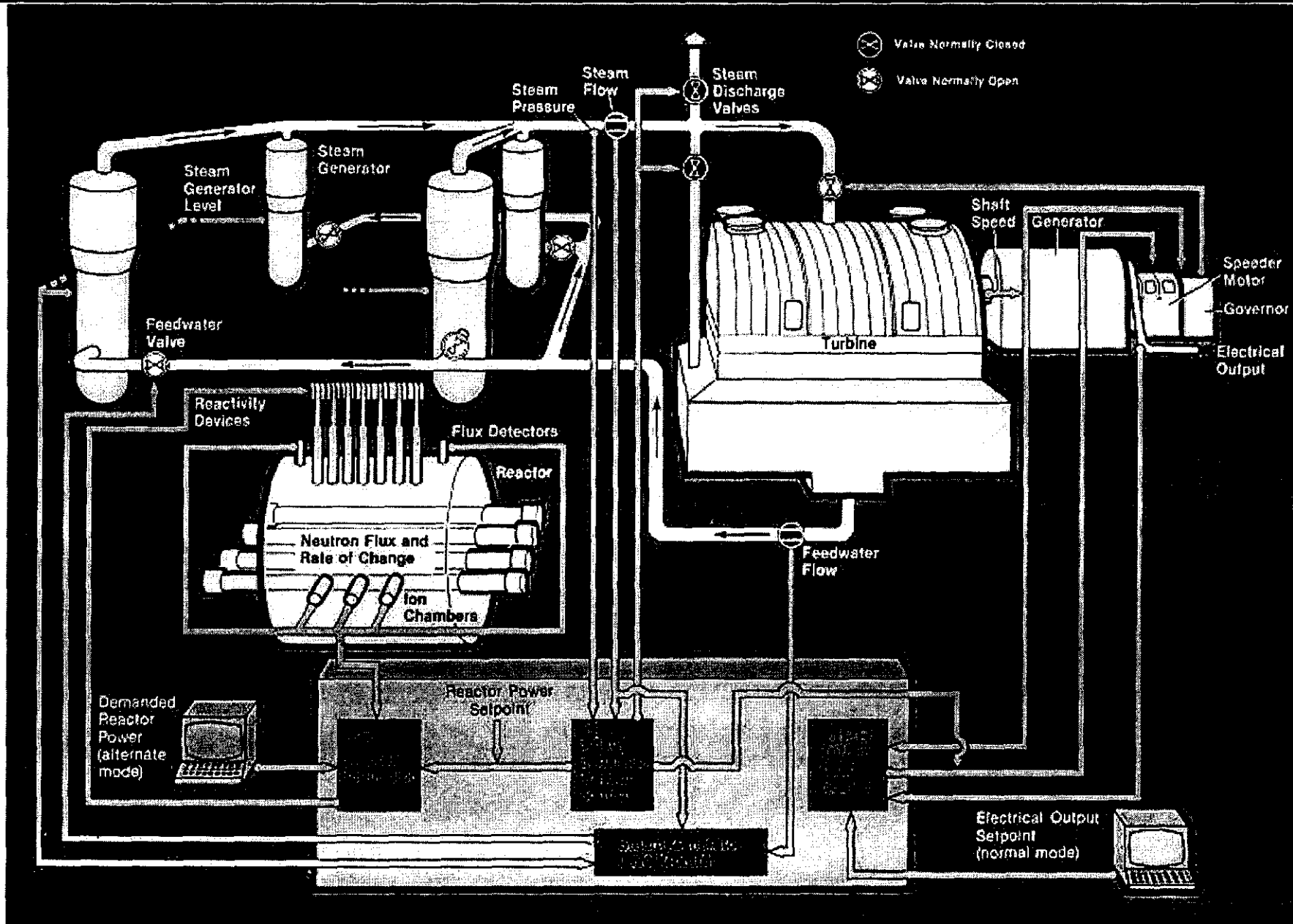


Figure 5: Overall Unit Control

## **6. REACTOR SHUTDOWN SYSTEMS (SDS#1 and SDS#2)**

- **there are two 'full capability' reactor shutdown systems, they are functionally and physically independent of each other, and each able to shut down the reactor;**
- **functional independence is provided by using different methods of shutdown: dropping solid neutron absorbing rods into the core for SDS#1, and injecting liquid poison into the moderator for SDS#2;**
- **physical independence is achieved by positioning the shutdown rods vertically through the top of the reactor, and the poison injection tubes horizontally through the sides of the reactor;**
- **the two shutdown systems respond automatically to both neutronic and process signals**
- **a very high level of independence is achieved by using diversity in:**
  - **the types of instruments used,**
  - **parameters measured**
  - **the control equipment hardware**
  - **software language**
  - **design and analysis teams.**

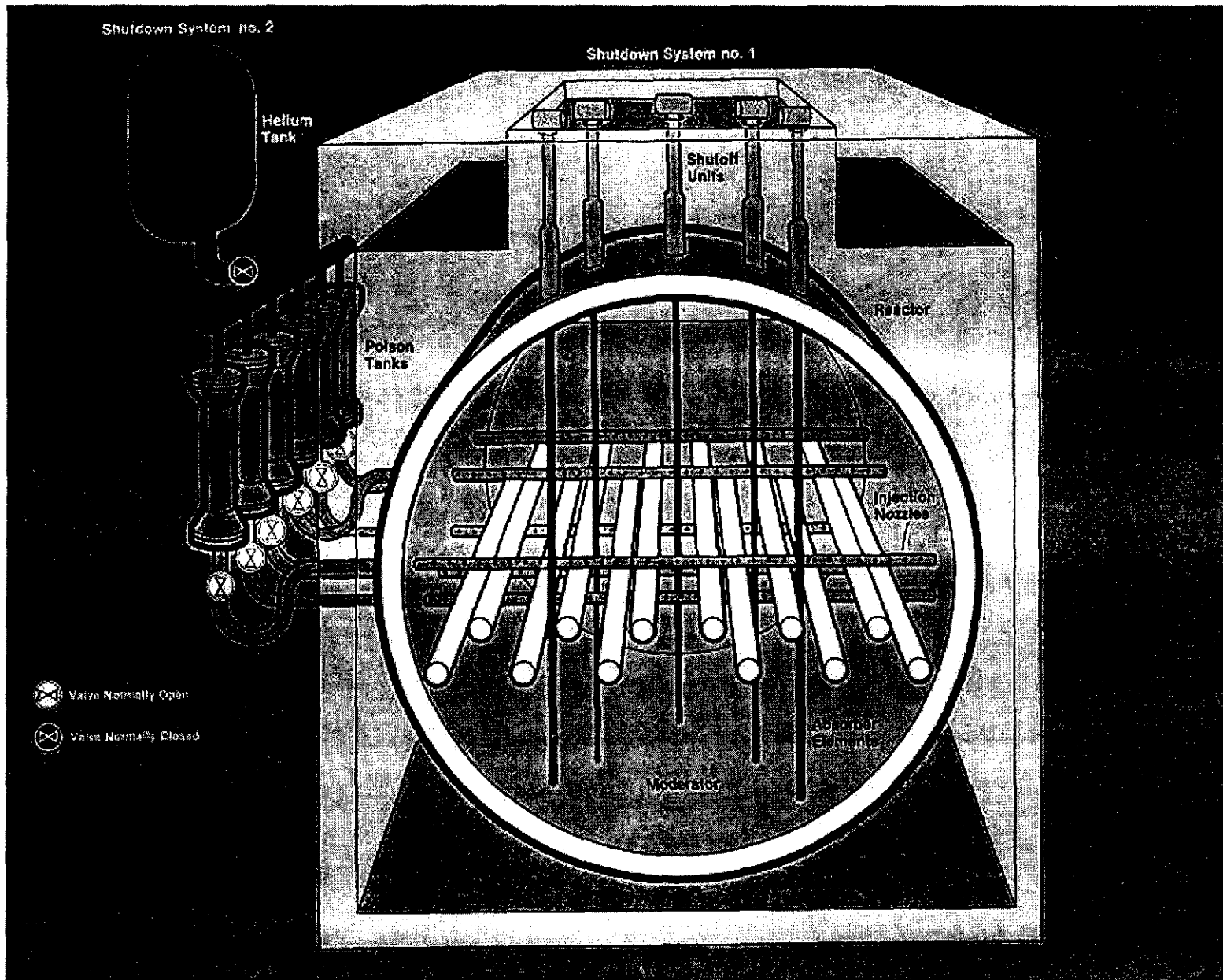
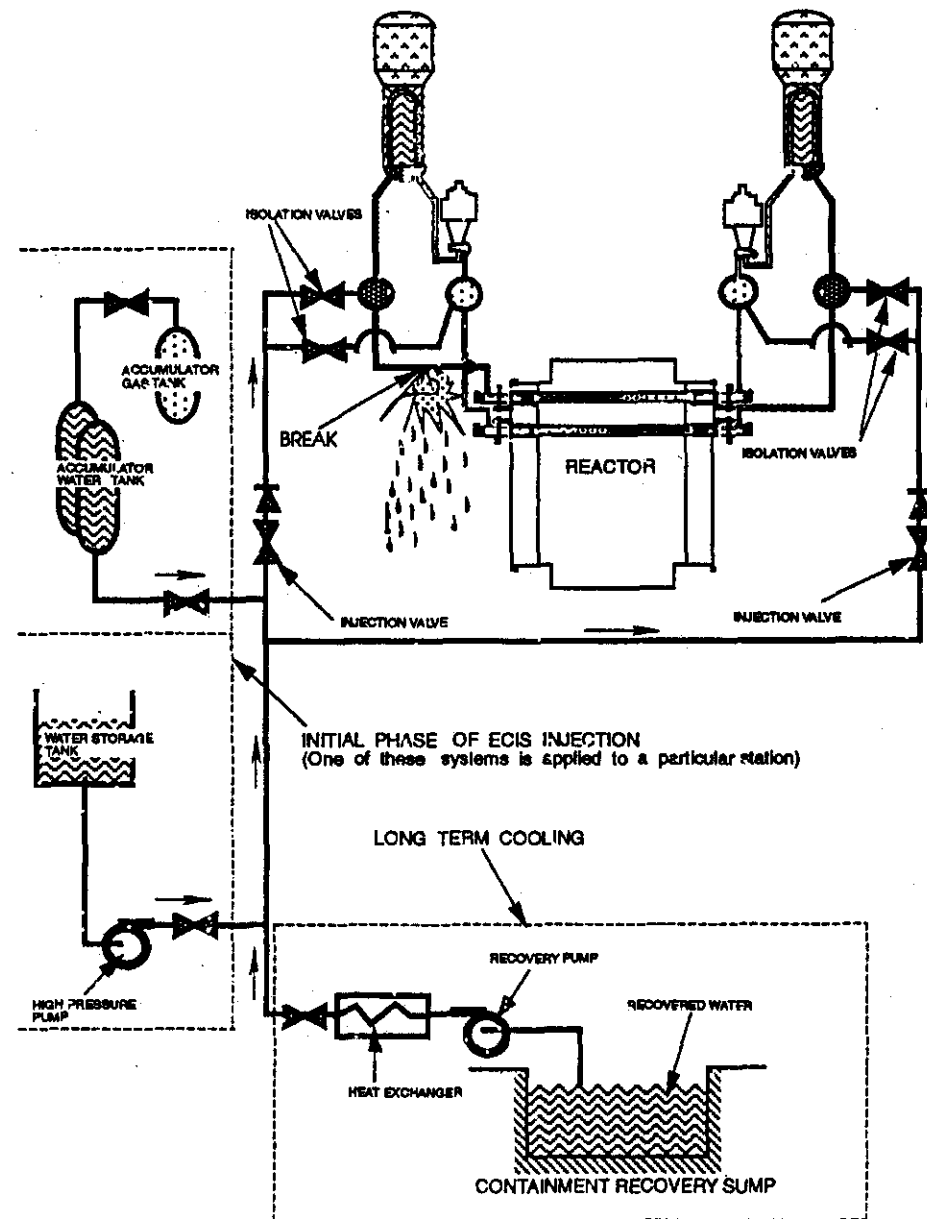


Figure 6: Reactor Shutdown Systems (SDS#1 and #2)

## 7. EMERGENCY CORE COOLING SYSTEM

- the system operates in the event of a loss of coolant accident (LOCA), and has three stages of operation: high, medium and low pressure;
- the initial injection of high pressure cooling water into the heat transport system is by opening the valve between the Gas Tank and the Water Injection Tanks (there is a corresponding opening of the boiler steam release valves to achieve rapid cooling of the boilers and further depressurization of the heat transport system);
- the source of medium pressure injection is the dousing tank, with either one of the two ECC pumps being able to supply 100% flow;
- low pressure operation uses the same ECC pumps, but with the water coming from the floor of the reactor building.



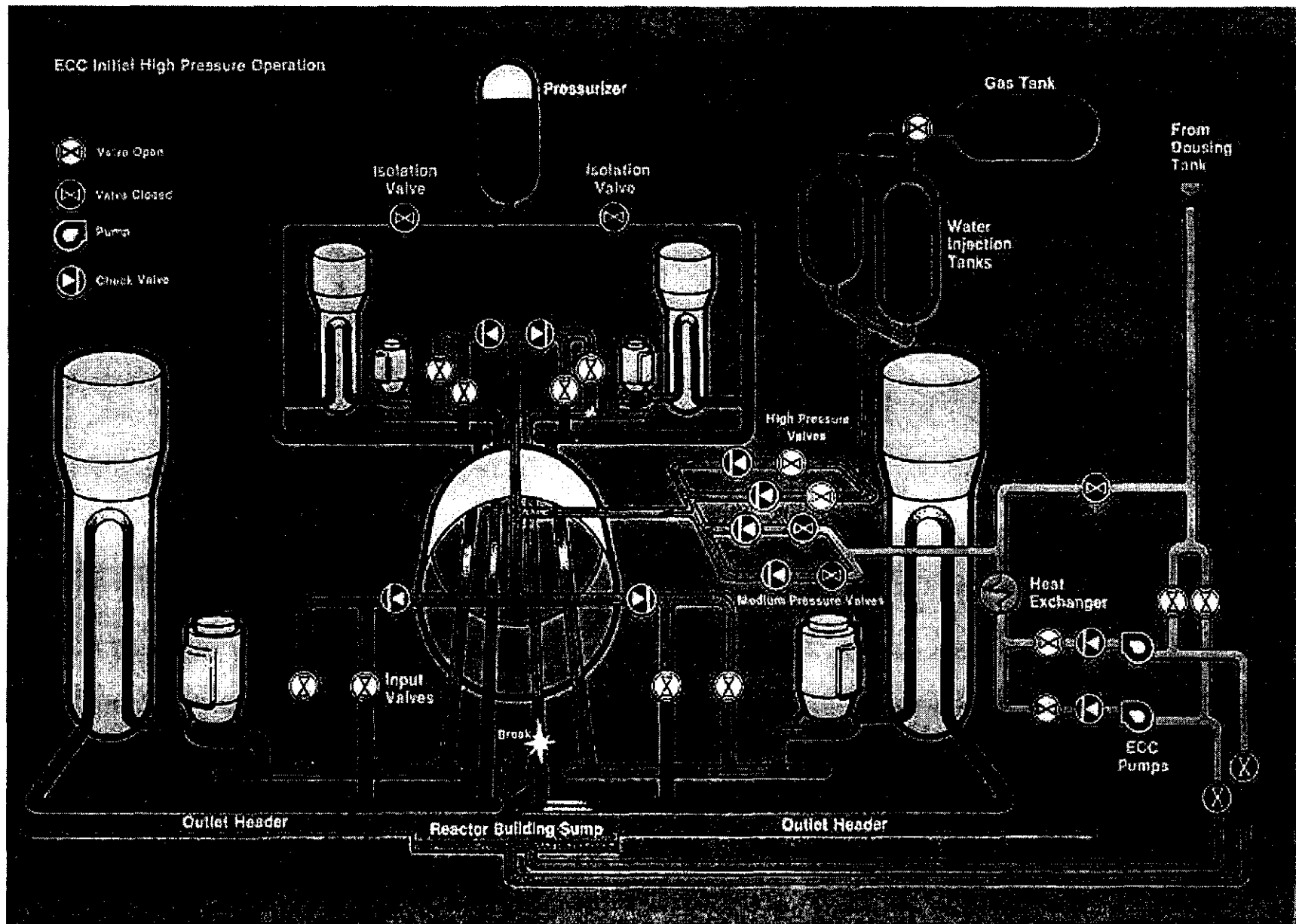
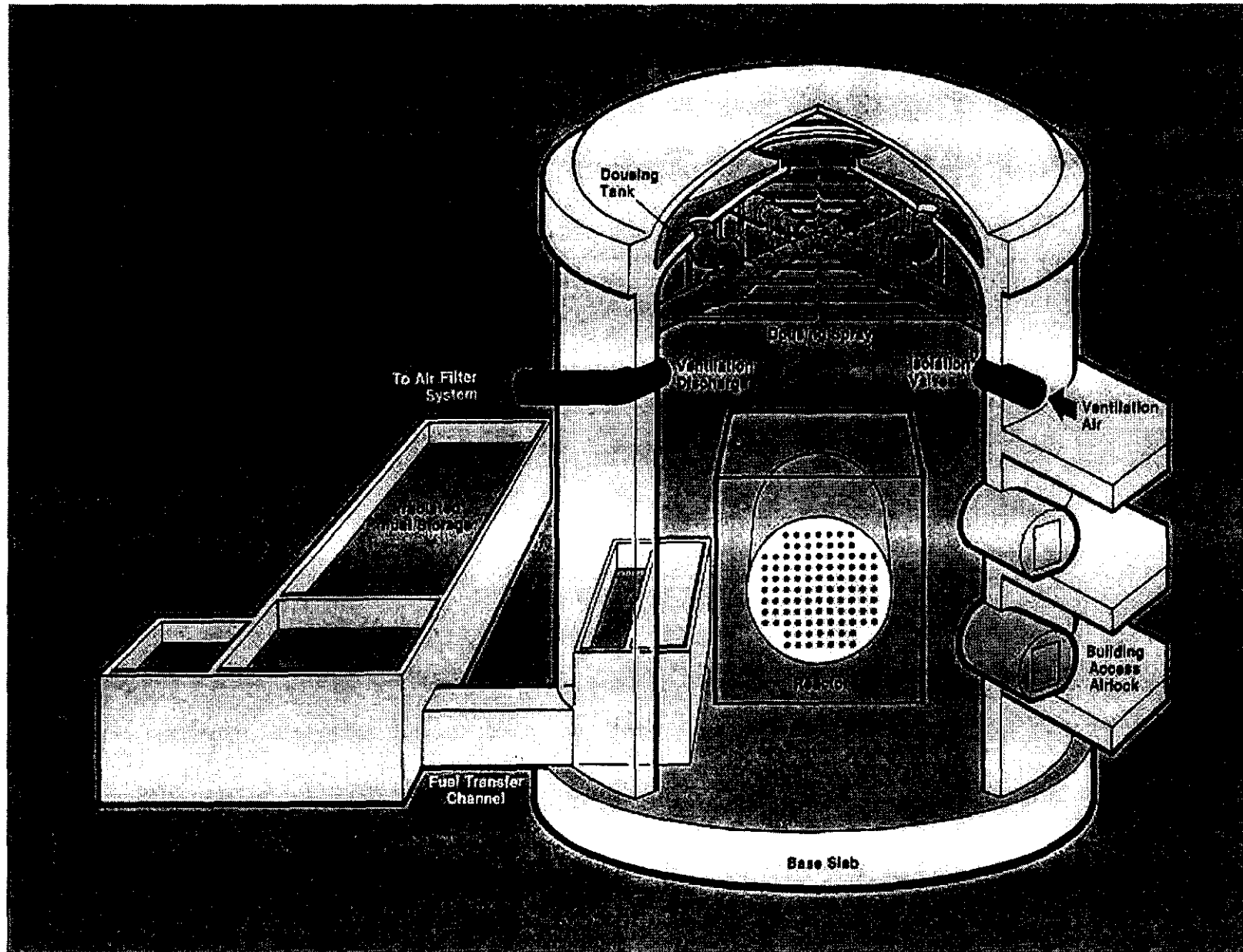


Figure 7: Emergency Core Cooling System

## 18. CONTAINMENT SYSTEM

- the following systems provide a sealed envelope around the nuclear steam supply systems if an accidental release of radioactivity is detected:
  - ⇒ plastic lined pre-stressed post-tensioned pressure-retaining concrete containment structure;
  - ⇒ automatic dousing system;
  - ⇒ air coolers that provide a long-term containment atmosphere heat sink
  - ⇒ filtered air discharge system;
  - ⇒ access airlocks;
  - ⇒ automatic containment isolation system that closes all reactor building penetrations open to the containment atmosphere when an increase in containment pressure or radioactivity level is detected;
- these systems are designed to withstand the maximum pressure which could occur following the largest postulated loss-of-coolant accident;

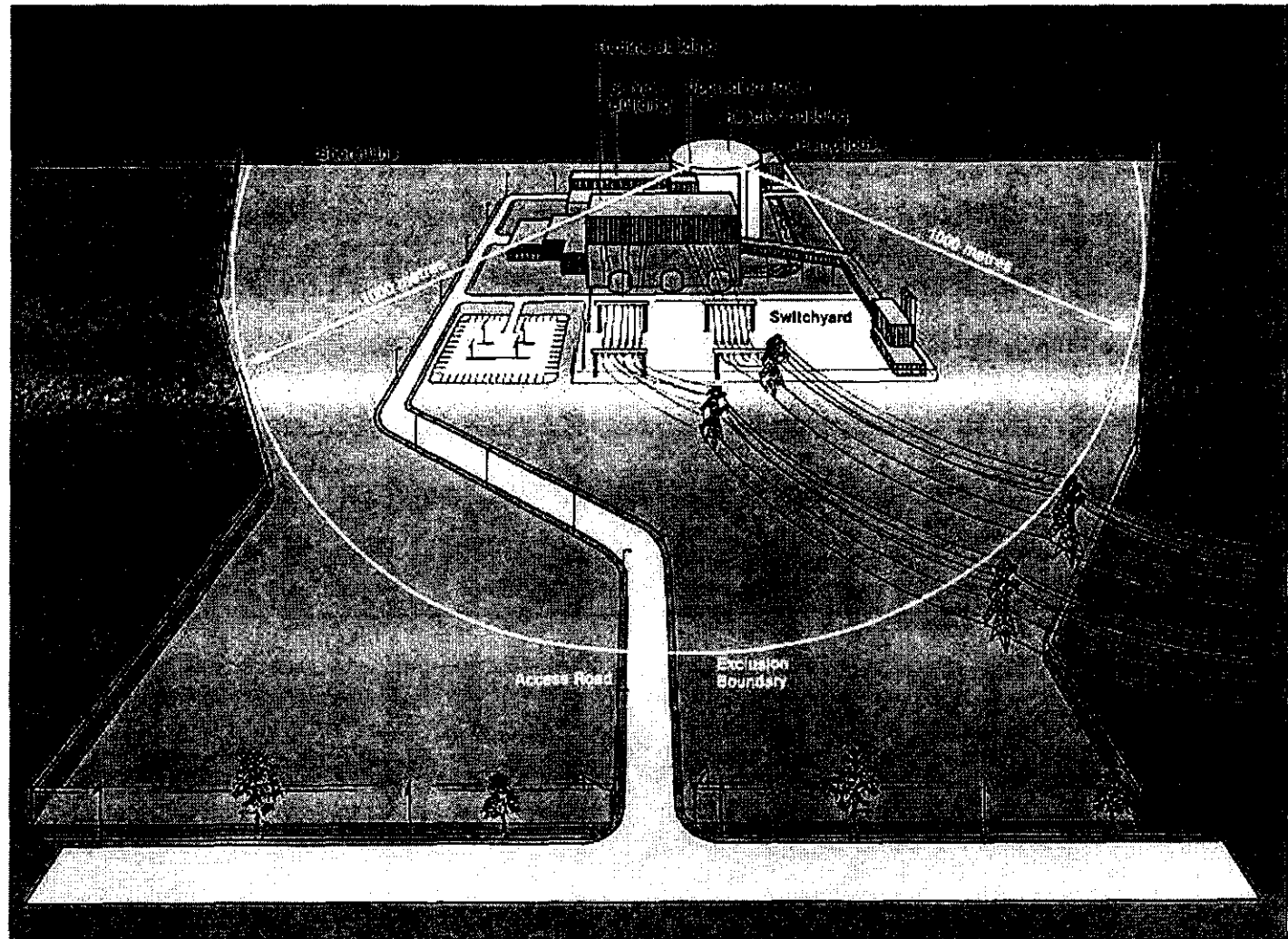


**Figure 8: Containment System**



## 9. SITE AND PLANT ARRANGEMENTS

- land area sufficient to provide the required exclusion zone (500 - 1000 meters)
- source of cooling water;
- connection to the electrical grid;
- geology suitable for foundations of the required structures;
- known level of seismic activity;
- transportation access.



## **CHAPTER 1: OVERALL UNIT**

### **MODULE E: SIMULATOR EXERCISES**

#### **MODULE OBJECTIVES:**

**At the end of this module, you will be able to:**

- 1. Star-up and initialize the Simulator;**
- 2. Find the parameters that are common to all the displays;**
- 3. Identify the parameters displayed on the Plant Overview and Turbine Generator pages;**
- 4. Maneuver unit power via the Unit Power Regulator page.**

## 1. SIMULATOR STARTUP

- double click on 'CANDU\_R4'
- on 'CANDU 9 Compact Simulator' screen click on 'OK' and 'STOP SERVER'
- when messages clear, double click anywhere on screen
- click 'OK' to 'Load Full Power IC?'
- the Simulator will display the 'Plant Overview' screen with all parameters initialized to 100% Full Power
- at the bottom right hand corner click on 'Run' to start the simulator

## 2. SIMULATOR INITIALIZATION

If at any time you need to return the Simulator to one of the stored Initialization Points, do the following:

- 'Freeze' the Simulator
- click on 'IC'
- click on 'Load IC'
- click on 'FP\_100.IC' for 100% full power initial state
- click 'OK' to 'Load C:\AECL\_P4\FP\_100.IC'
- click 'YES'
- click 'Return'
- Start the Simulator operating by selecting 'Run'.

### 3. LIST OF CANDU 9 COMPACT SIMULATOR DISPLAY SCREENS

1. Plant Overview
2. Shutdown Rods
3. Reactivity Control
4. Liquid Zones Control
5. Zonal Flux Trends
6. Flux Mapping
7. PHT Main Circuit
8. PHT Feed & Bleed
9. PHT Inventory Control
10. PHT Pressure Control
11. Bleed Condenser Control
12. Steam Generator Feed Pumps
13. Steam Generator Level Control Steam
14. Generator Level Trends
15. Steam Generator Level Manual Ctrl
16. Extraction Steam
17. Turbine Generator
18. RRS / DPR
19. UPR
20. Electrical GRP1 Class IV
21. Electrical GRP1 Class III
22. Electrical GRP1 Class I/II A
23. Electrical GRP1 Class I/II B
24. Electrical GRP1 Class I/II C
25. Elect GRP1 Class IV Loads 1
26. Elect GRP1 Class IV Loads 2
27. Elect GRP1 Class III Loads 1
28. Elect GRP1 Class III Loads 2
29. Trends

#### 4. COMPACT SIMULATOR DISPLAY COMMON FEATURES

Revision 4 of the CANDU 9 Compact Simulator is made up of 29 interactive display screens or pages. All of these screens have the same information at the top and bottom of the displays, as follows:

- top of the screen contains 21 plant alarms and annunciations; these indicate important status changes in plant parameters that require operator actions; each of these alarms will be discussed as part of the system that is generating it and/or is involved in the corrective action;
- top right hand corner shows the simulator status:
  - ⇒ the window under 'Labview' (this is the proprietary software that generates the screen displays) has a counter that is incrementing when Labview is running; if Labview is frozen (i.e. the displays cannot be changed) the counter will not be incrementing;
  - ⇒ the window displaying 'CASSIM' (this is the proprietary software that computes the simulation responses) will be green and the counter under it will not be incrementing when the simulator is frozen (i.e. the model programs are not executing), and will turn red and the counter will increment when the simulator is running;
- to stop (freeze) Labview click once on the 'STOP' sign at the top left hand corner; to restart 'Labview' click on the ⇒ symbol at the top left hand corner;
- to start the simulation click on 'Run' at the bottom right hand corner; to 'Stop' the simulation click on 'Freeze' at the bottom right hand corner;

## 5. COMPACT SIMULATOR DISPLAY COMMON FEATURES (continued)

- the bottom of the screen shows the values of the following major plant parameters:
  - ⇒ Reactor Neutron Power (%)
  - ⇒ Reactor Thermal Power (%)
  - ⇒ Generator Output (%)
  - ⇒ Main Steam Header Pressure (kPa)
  - ⇒ Steam Generator Level (m)
  - ⇒ OUC Mode ('Normal' or 'Alternate')
- the bottom left hand corner allows the initiation of two major plant events:
  - ⇒ 'Reactor Trip'
  - ⇒ 'Turbine Trip'

these correspond to hardwired push buttons in the actual control room;

- the box above the Trip buttons shows the display currently selected (i.e. 'Plant Overview'); by clicking and holding on the arrow in this box the titles of the other displays will be shown, and a new one can be selected by highlighting it;
- the remaining buttons in the bottom right hand corner allow control of the simulation one iteration at a time ('Iterate'); the selection of initialization points ('IC'); insertion of malfunctions ('Malf'); and calling up the 'Help' screen.

## 6. PLANT OVERVIEW PAGE

Shows a 'line diagram' of the main plant systems and parameters. No inputs are associated with this display. The systems and parameters displayed are as follows (starting at the bottom left hand corner):

- MODERATOR system is not simulated
- REACTOR is a 14 zone model, each zone being represented by a point kinetic model with six groups of delayed neutrons, and coupling coefficients that account for the interaction of the flux between adjacent zones; decay heat model uses a three group approximation; reactivity calculations include reactivity control and safety devices, Xenon, voiding in channels and power level changes. The parameters displayed are:
  - ⇒ Average Zone Level (% full)
  - ⇒ Neutron Power (% full power)
  - ⇒ Neutron Power Rate (%/ second)
- Heat Transport main loop, pressure and inventory control systems are shown as a single loop on the Plant Overview display, additional details will be shown on subsequent displays. The parameters displayed are:
  - ⇒ Reactor Outlet Header (ROH) and Reactor Inlet Header (RIH) average Temperature (°C) and Pressure (kPa)
  - ⇒ Pressurizer Level (m) and Pressure (kPa); D<sub>2</sub>O Storage Tank level (m)

## 6.1 PLANT OVERVIEW PAGE (continued)

- The four Steam Generators are individually modeled, but only the level measurements are shown separately, for the flows, pressures and temperatures average values are shown. The parameters displayed are:
  - ⇒ Boiler 1, 2, 3, 4 Level (m)
  - ⇒ Steam Flow (kg/sec)
  - ⇒ Steam Pressure (kPa)
  - ⇒ Steam Temperature (°C)
  - ⇒ Moisture Separator and Reheater (MSR) Drains Flow (kg/sec)
  - ⇒ Status of control valves is indicated by their colour: green is closed, red is open; the following valves are shown for the Steam System:
    - Main Steam Stop Valves (MSV) status only
    - Condenser Steam Discharge Valves (CSDV) status and % open
    - Atmospheric Steam Discharge Valves (ASDV) status and % open
- Generator output (MW) is calculated from the steam flow to the turbine
- Condenser and Condensate Extraction Pump (CEP) are not simulated
- Simulation of the feedwater system is very much simplified; the parameters displayed on the Plant Overview screen are:
  - ⇒ Total Feedwater flow to the steam generators (kg/sec)
  - ⇒ Average Feedwater temperature after High Pressure Heater (HPHX)
  - ⇒ Status of Boiler Feed Pumps (BFP) is indicated as red if any pumps are 'ON' or green if all the pumps are 'OFF'

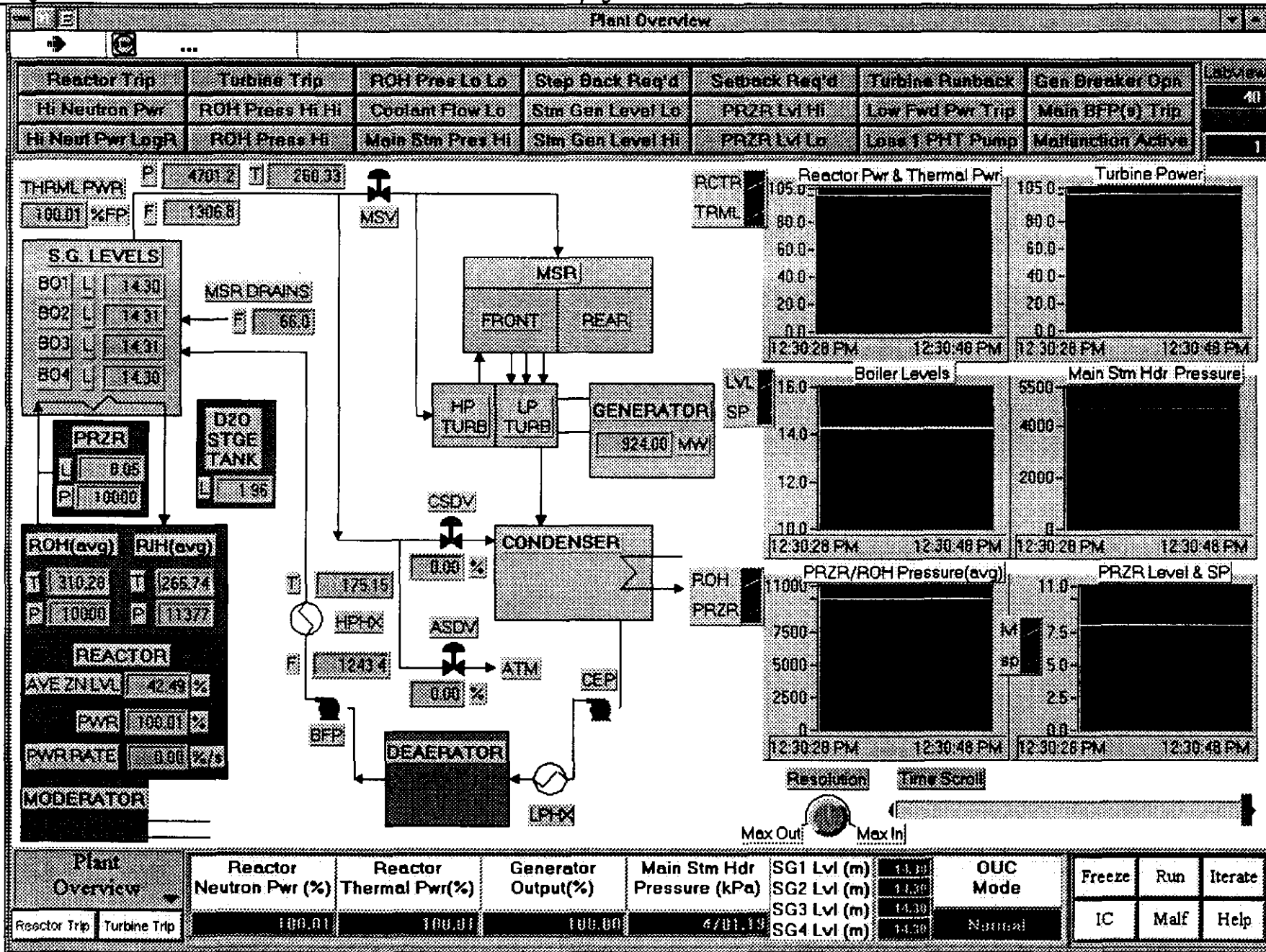


## 6.2 PLANT OVERVIEW PAGE (continued)

Six trend displays show the following parameters:

- Reactor Neutron Power and Reactor Thermal Power (0-100%)
- Turbine Power (0-100%)
- Boiler Levels - actual and setpoint (m)
- Main Steam Header Pressure (kPa)
- Pressurizer and Reactor Outlet Header (average) Pressure (kPa)
- Pressurizer Level - actual and setpoint (m)

Note that while the simulator is in the 'Run' mode, all parameters are being continually computed and all the displays are available for viewing and inputting changes.



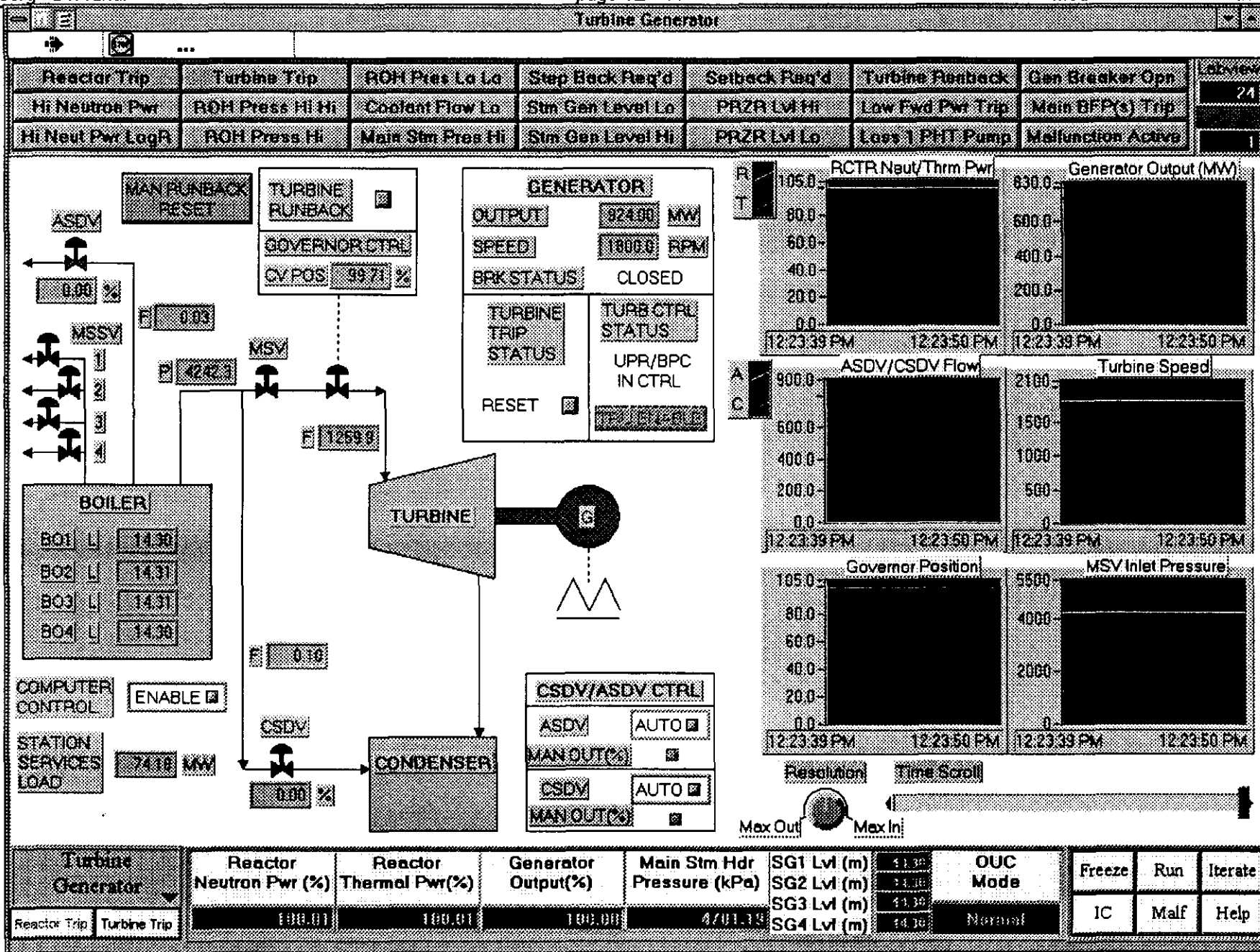
## 7. TURBINE GENERATOR PAGE

Shows the main parameters and controls associated with the Turbine and the generator. The parameters displayed are:

- **Boiler 1, 2, 3, 4 Level (m)**
- **status of Main Steam Safety Valves (MSSV)**
- **status, opening and flow through the Atmospheric Steam Discharge Valves (ASDV) and the Condenser Steam Discharge Valves (CSDV)**
- **Steam Flow to the Turbine (kg/sec)**
- **Governor Control Valve Position (% open)**
- **Generator Output (MW)**
- **Turbine/Generator Speed of Rotation (rpm)**
- **Generator Breaker Trip Status**
- **Turbine Trip Status**
- **Turbine Control Status**
- **All the trend displays have been covered elsewhere or are self explanatory**

The following pop-up menus are provided:

- **TURBINE RUNBACK - sets Target (%) and Rate (%/sec) of runback when 'Accept' is selected**
- **TURBINE TRIP STATUS - Trip or Reset**
- **ASDV and CSDV AUTO/MANUAL Control - AUTO Select, following which the Manual Position of the valve may be set**



## 8. UPR PAGE

This screen permits control of station load setpoint and its rate of change while under Unit Power Regulator (UPR) control, i.e. 'normal' mode. Control of the Main Steam Header Pressure is also through this screen, but this is not usually changed under normal operating conditions.

- OUC (overall Unit Control) MODE can be changed from NORMAL to ALTERNATE.
- TARGET LOAD - on selection Station Load (%) and Rate of Change (%/sec) can be specified; change becomes effective when 'Accept' is selected.
  - ⇒ The OPERATOR INP TARGET is the desired setpoint inserted by the operator; the CURRENT TARGET will be changed at a POWER RATE specified by the operator.
  - ⇒ Note that the RANGE is only an advisory comment, numbers outside the indicated range of values may be input on the Simulator.
- MAIN STEAM HEADER PRESSURE SETPOINT (MPa) - alters the setpoint, which is rarely done during power operation. Caution must be exercised when using this feature on the Simulator, since the requested change takes place in a step fashion as soon as the change is made; changes should be made in increments of 0.1 MPa.

UPR

Reactor Trip	Turbine Trip	ROH Pres Lo Lo	Step Back Req'd	Setback Req'd	Turbine Runback	Gen Breaker Opn	Labview
Hi Neutron Pwr	ROH Pres Hi Hi	Coolant Flow Lo	Stm Gen Level Lo	PRZR Lvl Hi	Low Fwd Pwr Trip	Main BCP(s) Trip	11
Hi Neut Pwr LogR	ROH Pres Hi	Main Stm Pres Hi	Stm Gen Level Hi	PRZR Lvl Lo	Loss 1 PHT Pump	Malfunction Active	1

OUC MODE: NORMAL

RCTR: TRML

### UNIT POWER RATE & TARGET LOAD

CONTROLLED VARIABLE	CURRENT TARGET	OPERATOR INP TARGET	RANGE
TARGET LOAD(%) <input checked="" type="checkbox"/>	100.00	100.00	5 TO 100
POWER RATE (%/S)	0.80	0.80	0.01 TO 1

Reactor Pwr & Thermal Pwr

Main Steam Hdr Pressure & SP

### MAIN STEAM HEADER PRESSURE SETPOINT

CONTROLLED VARIABLE	CURRENT TARGET	OPERATOR INP TARGET	RANGE
MAIN STM HDR PRES SETPOINT(MPa) <input checked="" type="checkbox"/>	4.701	4.701	4 TO 5

Current Target Load & Turbine Pwr

Boiler Level

Resolution: 0 Time Scroll: 0

Max Out 0 Max In 0

UPR System	Reactor Neutron Pwr (%)	Reactor Thermal Pwr(%)	Generator Output(%)	Main Stm Hdr Pressure (kPa)	SG1 Lvl (m)	SG2 Lvl (m)	SG3 Lvl (m)	SG4 Lvl (m)	OUC Mode	Freeze	Run	Iterate
Reactor Trip	100.00	100.00	100.00	4.701	11.30	11.30	11.30	11.30	Normal	IC	Malf	Help

## 9. SIMULATOR EXERCISES

### 9.1 POWER MANEUVER: 10% Power Reduction and Return to Full Power

- Initialize Simulator to 100% full power
- verify that all parameters are consistent with full power operation.
- select the UPR page, and change the scale on the "Reactor Pwr & Thermal Pwr" and "Current Target Load & Turbine Pwr" graphs to be between 80 and 110 percent, the "Main Steam Hdr Pressure & SP" to 4500 and 5000 kPa, "Boiler Level" to 13 and 15 meters, and set "Resolution" to "Max Out".
- reduce unit power in the 'normal' mode, i.e.
  - ⇒ using the UPR display
  - ⇒ select 'TARGET LOAD (%)' pop-up menu
  - ⇒ In pop-up menu lower 'target' to 90.00% at a 'Rate' of 1.0 %/sec
  - ⇒ 'Accept' and 'Return'
- observe the response of the displayed parameters until the transients in Reactor Power and Steam Pressure are completed (approximately 4 minutes and full time scale on the graph) without freezing the Simulator and/or stopping Labview, and explain the main changes
- continuing the above operation, raise "UNIT POWER" to 100% at a rate of 1.0%FP/sec.

## 9.2 RESPONSE TO POWER MANEUVER

- initialize the Simulator to 100%FP, reduce power using UPR in 25% steps at 0.5%/sec (trip the reactor for the 0% state) and record the following values:

Parameter	Unit	100%	75%	50%	25%	0%	Comments
Reactor Power	%						
ROH Pressure	MPa						
ROH Temperature	°C						
RIH Pressure	MPa						
RIH Temperature	°C						
Pressurizer Level	m						
HT Pump Flow	Mg/s						
Boiler Pressure	MPa						
Boiler Temperature	°C						
Boiler Level	m						
Steam Flow	kg/s						
Feedwater Flow	kg/s						
Turbine-Generator Power	%						

Under “Comments” please note type of parameter change as a function of reactor power 0% → 100%FP: constant, linear increase or decrease, non-linear increase or decrease



### 9.3 TEMPERATURE PROFILE ACROSS A CANDU 9 UNIT AT FULL POWER

- Initialize the Simulator to 100% Full Power.
- Record the values of the parameters in the table below.

Station Equipment	Pressure (kPa)	Temperature (°C)
Reactor Inlet Header		
Reactor Outlet Header		
Steam Generator		
HP Turbine Exhaust	900	170
LP Turbine Inlet	900	230
Condenser	5	35
LP Heater Outlet	700	100
Deaerator		130
Boiler Feedpump Inlet		
HP Heater Outlet		
Preheater Outlet		

- Plot these parameters on the attached grid.

